



Parts Manual

Proportioning Unit

evolution G-125 A / G-200 A

Issue 6.2 04/12/25
Ref. NR-00007-ENG



Before installing the unit and starting it up, carefully read all the technical and safety documentation included in the Manual Service. Pay special attention to the information to know and understand the handling and the conditions of use of the unit. All of the information is aimed at enhancing User Safety and avoiding possible breakdowns derived from the incorrect use of the unit.



WARRANTY

HI-TECH SPRAY EQUIPMENT, S. A. (hereinafter "HI-TECH") grants this Limited Guarantee to the original buyer (hereinafter the "Client") for the unit and the original accessories given with the unit (hereinafter the "Product") against any fault in the design, materials or manufacture of the Product at the time of the first purchase by the user and for a duration of two (2) years thereafter, except in the case of hoses and TSU's, which will have a warranty period of one (1) year. Additionally, for any other product manufactured by external suppliers, the warranty period will be as specified by the manufacturer.

If during the guarantee period and under normal conditions of use, the Product should fail to work correctly due to defects of design, material or manufacture, the authorised distributor of the country where the HI-TECH Product or technical assistance service has been purchased shall repair or replace the Product in accordance with what is established in the following:

CONDITIONS

- a) The validity of this guarantee will be subject to the presentation of the original invoice issued by the HI-TECH authorised distributor for the sale of the Product along with the Product handed over for repair or replacement, which must show the date of purchase and the serial number. HI-TECH reserves the right to refuse to give the guarantee service when the indicated data fail to appear on the invoice or have been modified after the purchase of the Product.
- b) The repaired or replaced Product will continue to maintain the original guarantee for the time remaining until the end of the guarantee or for three (3) months from the repair date, if the remaining period of the original guarantee were shorter.
- c) This guarantee will not be applied to the faults in the Product caused by its faulty installation, the natural wear and tear of the components, any use other than that considered normal for this Product or which should fail to strictly comply with the instructions of use provided by HI-TECH; due to accident, carelessness, adjustments, alterations or modifications of the Product not authorised by HI-TECH or due to the use of accessories, heating devices, pumping equipment and/or dispensers that have not been approved or manufactured by HI-TECH.
- d) The guarantee applicable to the components and accessories forming part of the Product and which have not been made by HI-TECH will be limited to the guarantee offered by the original manufacturer thereof.

HI-TECH WILL NOT RECOGNISE ANY EXPRESS ORAL OR WRITTEN GUARANTEES OTHER THAN THIS PRINTED LIMITED GUARANTEE. ALL IMPLICIT GUARANTEES, INCLUDING, WITHOUT LIMIT, ADAPTATION FOR A SPECIFIC USE, ARE SUBJECT TO THE DURATION OF THIS WRITTEN GUARANTEE. HI-TECH DOES NOT ASSUME ANY KIND OF COMMITMENT OR RESPONSIBILITY FOR ALL POSSIBLE DAMAGE OR EXPENSE CAUSED BY FAULTS IN THE OUTPUT OF THE PRODUCT, ITS WORKING OR THE DISPENSING OF MATERIAL THROUGH THE PRODUCT, INCLUDING, WITHOUT LIMITATION, ALL EXPENSES CAUSED BY DAMAGE TO PEOPLE OR PROPERTY. EQUALLY, HI-TECH WILL IN NO CASE ACCEPT LIABILITY FOR THE LOSS OF SPECULATIVE PROFITS OR COMMERCIAL LOSSES. ALL REPAIRS OR REPLACEMENT OF FAULTY PRODUCTS WILL CONSTITUTE THE COMPREHENSIVE FULFILMENT OF HI-TECH'S OBLIGATIONS WITH RESPECT TO THE CLIENT. HI-TECH DOES NOT IN ANY WAY GUARANTEE THE SUITABILITY OR APTITUDE OF ITS PRODUCT FOR ANY PARTICULAR PURPOSE OR APPLICATION.

All information provided on components which have not been manufactured by HI-TECH and which is based on reports received from the original manufacturer, though considered precise and reliable, is provided without any guarantee or responsibility of any explicit or implicit kind.

All concession, sale or financial leasing of the Product by HI-TECH in no case explicitly or implicitly constitutes any authorisation, acceptance or concession for the use of any rights or patents, nor does it encourage, nurture or back their infringement.

The restrictions on the guarantee suppose no limitation on the legal rights of the consumer established in applicable national legislation, nor do they affect any rights derived from the bargain and sale agreement between the consumer and supplier.



Parts Manual

All information provided in this manual has been included in the confidence that it is true, although it does not constitute any responsibility or implicit or explicit guarantee. HI-TECH reserves the right at any time and without prior warning to make all improvements and modifications necessary to this manual, in order to rectify any possible typographical errors, increase the information contained or insert the changes caused to the characteristics and performance of the unit.

SAFETY AND HANDLING

The equipment described in this manual has been designed and manufactured in compliance with the following European Directives, following as application guide the harmonized standards detailed and in conformity with the relevant UK Statutory Instruments (and their amendments):

2006/42/EC Machinery Directive

2014/35/EU Low Voltage Directive

2014/30/EU EMC Directive

2011/65/EU RoHS Directive with amendment 2015/863

2012/19/EU Directive on waste electrical and electronic equipment

Standards used:

EN ISO 12100:2010

EN 60204-1:2018

EN IEC 61000-6-4:2019

EN IEC 61000-6-2:2019

EN IEC 63000:2018



Electrical products cannot be thrown out with the rubbish. They must be taken to a dedicated collection point for an environmentally sound disposal in accordance with local regulations. You must contact your local collective or retailer for information about recycling. Before leaving WEEE at appropriate collection facilities, batteries must be removed and disposed of separately for proper recycling. The packaging materials are recyclable. Dispose of packaging materials in an environmentally sound manner and place them at the disposal of recycling sectors.

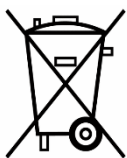

TRANSPORT AND STORAGE

Proper precautions must be taken so that the equipment can withstand the effects of transport and storage temperatures between -25°C and $+55^{\circ}\text{C}$ or up to $+70^{\circ}\text{C}$ for short periods that do not exceed 24 hours. Also, appropriate means to prevent damage from moisture, vibrations or shocks must be foreseen.

PROPORTIONING UNIT evolution G-125 A / G-200 A

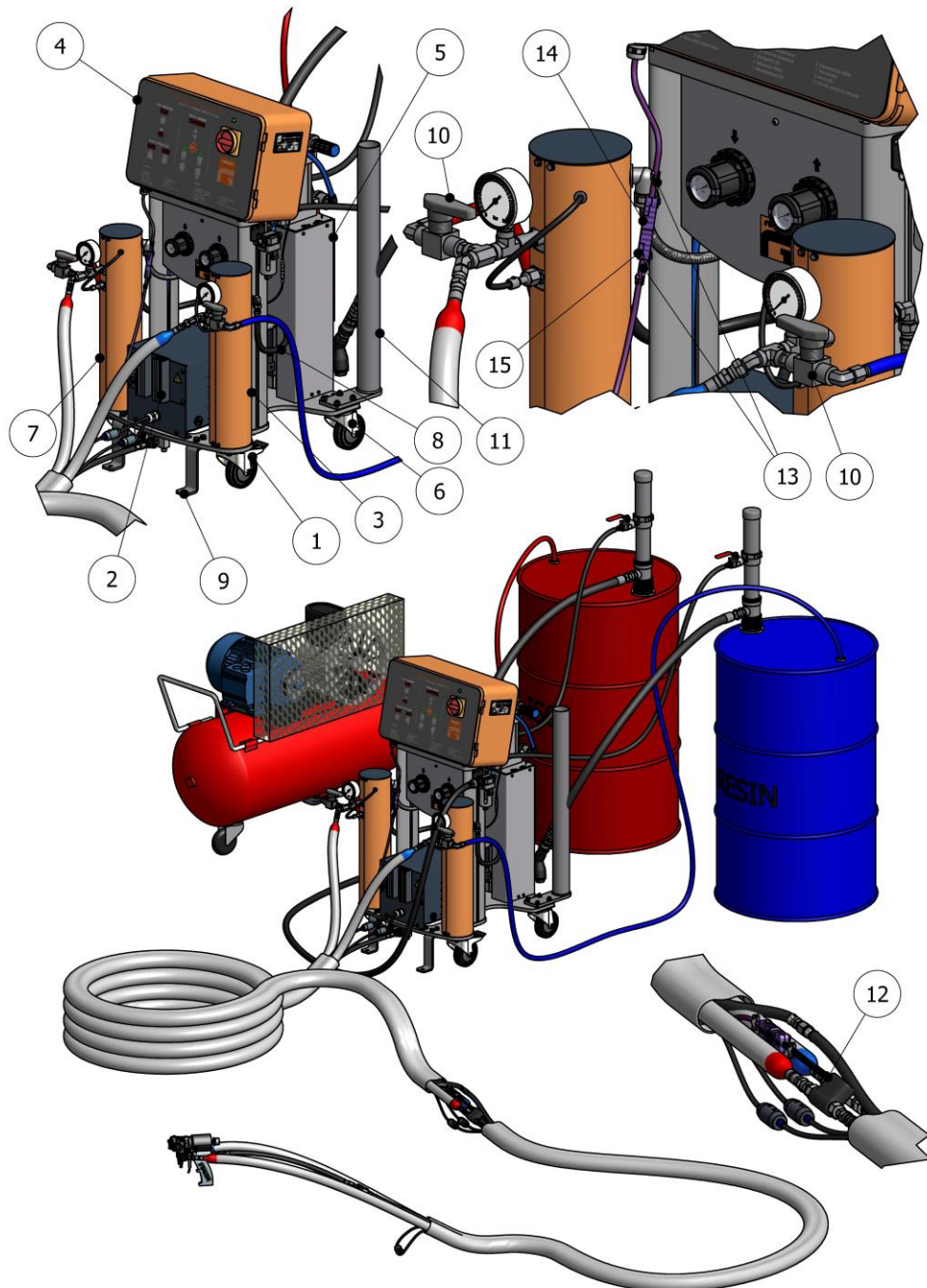

Figure 1. Proportioning Unit evolution G-125 A / G-200 A model

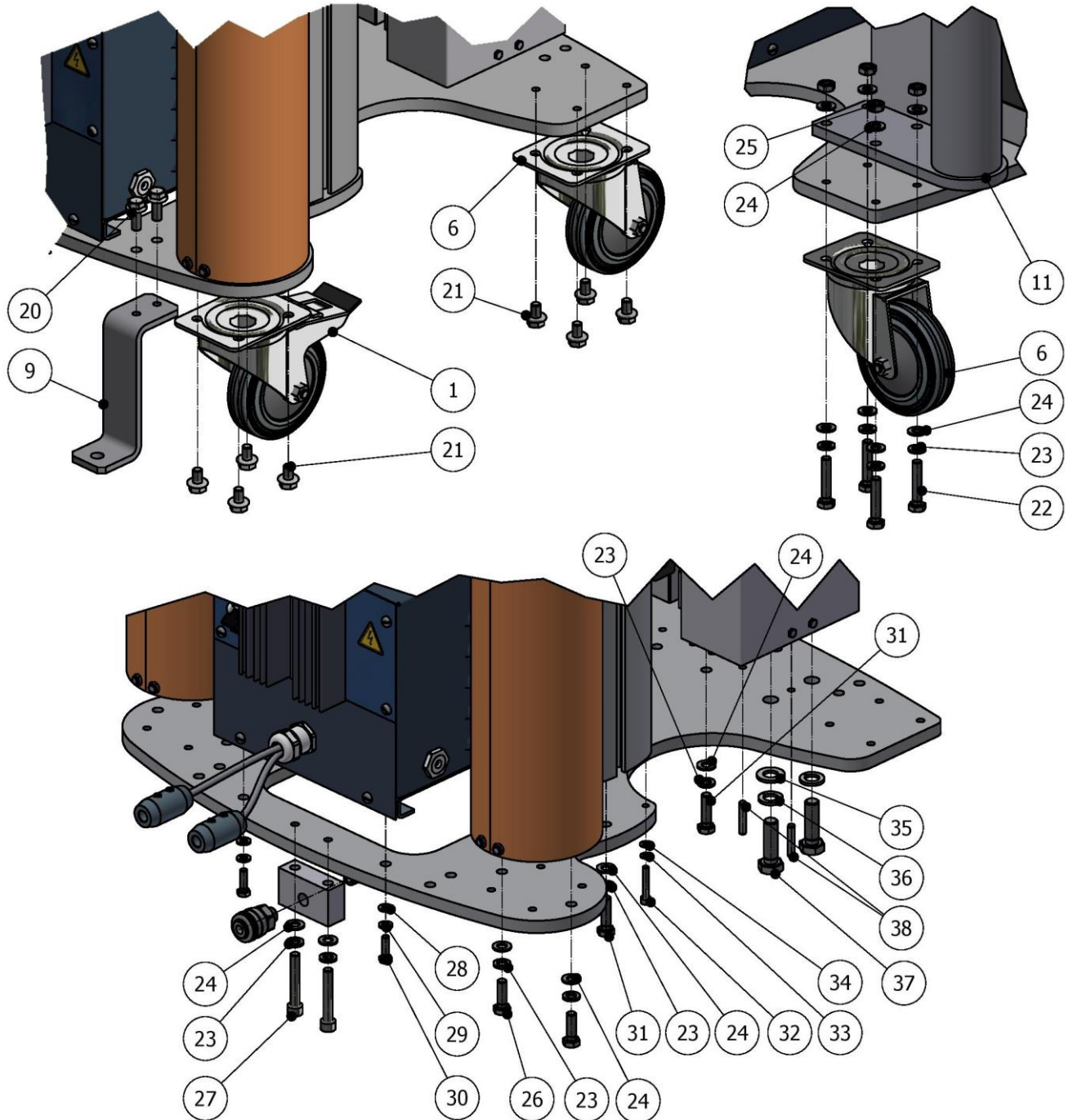

Figure 2. Generic Unions Detail, Proportioning Unit evolution G-125 A / G-200 A model



Table 1. Proportioning Unit evolution G-125 A / G-200 A model, Parts List

Ref.	Description	Part Number	Qty.
1	Front Wheel With Brake	MQ-02012	2
2	Hose Transformer	EL-00127-06	1
3	“R” Primary Heater	See Table 2	1
4	Electrical Console Assembly	See Table 4	1
5	Motor/Pump Assembly	See Table 5	1
6	Back Wheel	MQ-02013	2
7	“A” Primary Heater	See Table 3	1
8	Pump/Heater Hose Assy.	MA-00036	2
9	“Z” Bracket	MQ-02014	2
10	Recirculation Kit (OPTIONAL)	See Page 37, 38 & 40	1
11	Transfer Pump Bracket	MQ-02015-00	2
12	Hose Temperature Control Sensor	EL-00051-00E	1
13	Clamp Connector Sensor	EL-00096-86	1
14	Male Connector Sensor	EL-00096-84	1
15	Female Connector Sensor	EL-00096-85	1
16			
17			
18			
19			
20	Hex. Cap Flange Screw	TN-00507	4
21	Hex. Cap Flange Screw	TN-00504	16
22	Hex. Cap Screw	TN-00375	(8)
23	Block Washer	TN-00028	14 (8)
24	Flat Washer	TN-00119	14 (16)
25	Hex. Nut	TN-00029	(8)
26	Hex. Cap Screw	TN-00146	4
27	Allen Screw	TN-00090	2
28	Flat Washer	TN-00024	4
29	Block Washer	TN-00025	4
30	Hex. Cap Screw	TN-00276	4

Quantities in parentheses, for versions with transfer pump support.



Table 2. R-Primary Heater Reference List

Reference	Description
CLH-02002-00A	R Primary Heater 5000 W For # 7.6 Pump Size (G-125 A Standard)
CLH-02002-00B	R Primary Heater 6000 W For #4.5 Pump Size (G-200 A Standard)
CLH-02002-00C	R Primary Heater 5000 W For Special Pump Size (G-125 A OPTIONAL)

Table 3. A-Primary Heater Reference List

Reference	Description
CLH-02001-00A	A Primary Heater 5000 W For # 7.6 Pump Size (G-125 A Standard)
CLH-02001-00B	A Primary Heater 6000 W For #4.5 Pump Size (G-200 A Standard)
CLH-02001-00C	A Primary Heater 5000 W For Special Pump Size (G-125 A OPTIONAL)

Table 4. Electrical Console Reference List

Reference	Description
EL-00027-00	Electrical Console Assy. G-125 A Model
EL-00027-TSU	Electrical Console Assy. with TCS G-125 A Model(OPTIONAL)
EL-00139-00	Electrical Console Assy. G-200 A Model with TCS



Table 5. Motor/Pump Assembly Reference List

Reference		Description
ISO	POL	
PU-02015-A125	PU-02015-R125	Motor/Pump Assembly 2.9 Size
PU-02011-A125	PU-02011-R125	Motor/Pump Assembly 3.2 Size
PU-02001-A125	PU-02001-R125	Motor/Pump Assembly 4.5 Size (G-200 A) *
PU-02009-A125	PU-02009-R125	Motor/Pump Assembly 4.7 Size
PU-02005-A125	PU-02005-R125	Motor/Pump Assembly 5.1 Size
PU-02002-A125	PU-02002-R125	Motor/Pump Assembly 5.7 Size
PU-02003-A125	PU-02003-R125	Motor/Pump Assembly 6.3 Size
PU-02006-A125	PU-02006-R125	Motor/Pump Assembly 6.7 Size
PU-02013-A125	PU-02013-R125	Motor/Pump Assembly 7.2 Size
PU-02000-A125	PU-02000-R125	Motor/Pump Assembly 7.6 Size (G-125 A) #
PU-02012-A125	PU-02012-R125	Motor/Pump Assembly 9.0 Size
PU-02016-A125	PU-02016-R125	Motor/Pump Assembly 11.8 Size
PU-02014-A125	PU-02014-R125	Motor/Pump Assembly 13.5 Size

Note: (#) The standard proportioning pump size for G-125 A is #7.6, (*) for G-200 A is #4.5. Different sizes are available under order (refer to NR-00045-ENG manual). For delivery time, please consult with Marketing department.



ELECTRICAL CONSOLE evolution G-125 A MODEL

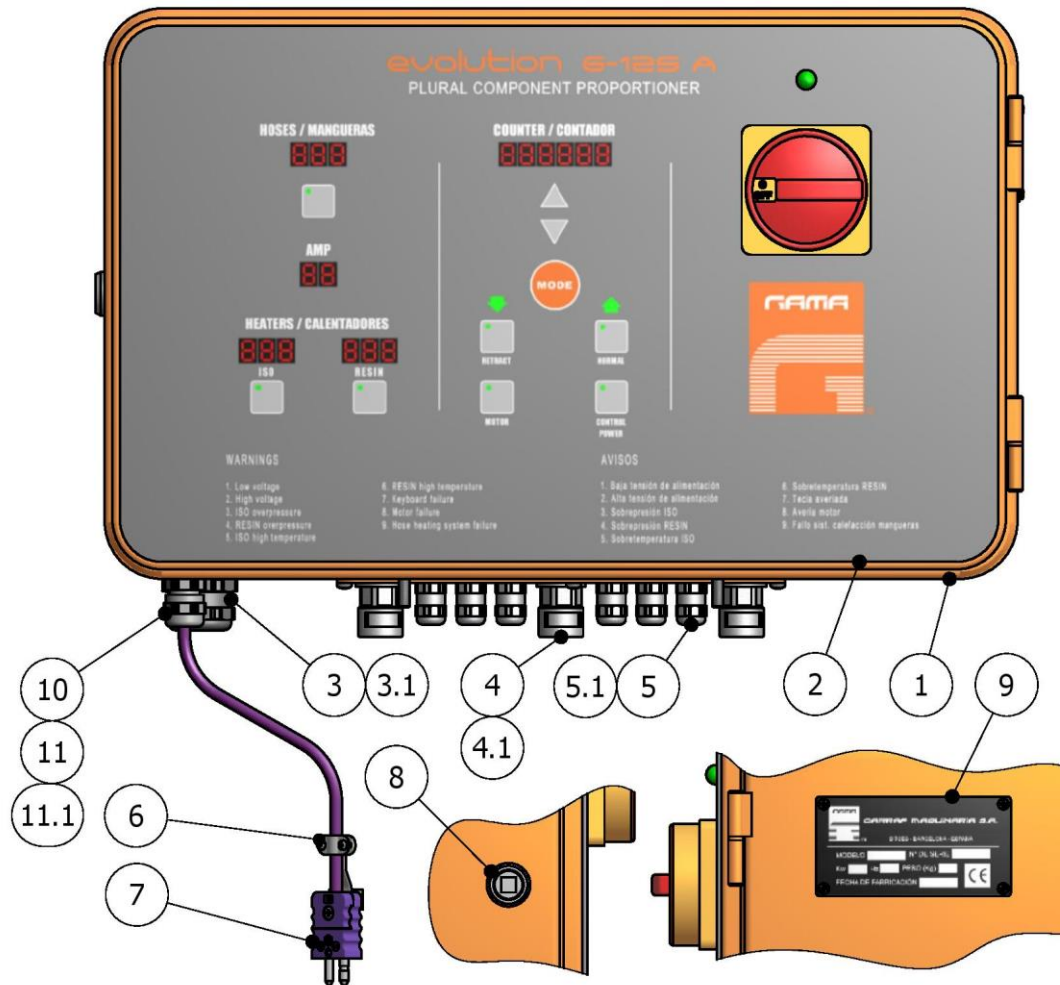

Figure 3. Electrical Console evolution G-125 A Model

**Table 6. Electrical Console evolution G-125 A Model, Parts List**

Ref.	Description	Part Number	Qty.
1	Electrical Console	EL-00027-01	1
2	Bezel & Electric Circuit Assembly	EL-00015-00	1
3	Cable Connector	EL-00088-01	1
3.1	Nut (not shown)	EL-00090-03	1
4	Strain Relief	EL-00087-00	3
4.1	Nut (not shown)	EL-00090-01	3
5	Strain Relief	EL-00088-00	6
5.1	Nut (not shown)	EL-00090-00	6
6	Connector Sensor Clamp	EL-00096-86	1 (*)
7	Male Connector Sensor	EL-00096-84	1 (*)
8	Lock Electrical Console	EL-00034	1
9	Standard Features Bezel	MQ-01010	1
10	Strain Relief	EL-00088-05	1 (*)
11	Plug	EL-00088-08	1
11.1	Nut (not shown)	EL-00090-06	1

N.B.:

The indicated parts () only are mounted on version with TCS.*



ELECTRICAL CONSOLE evolution G-200 A MODEL

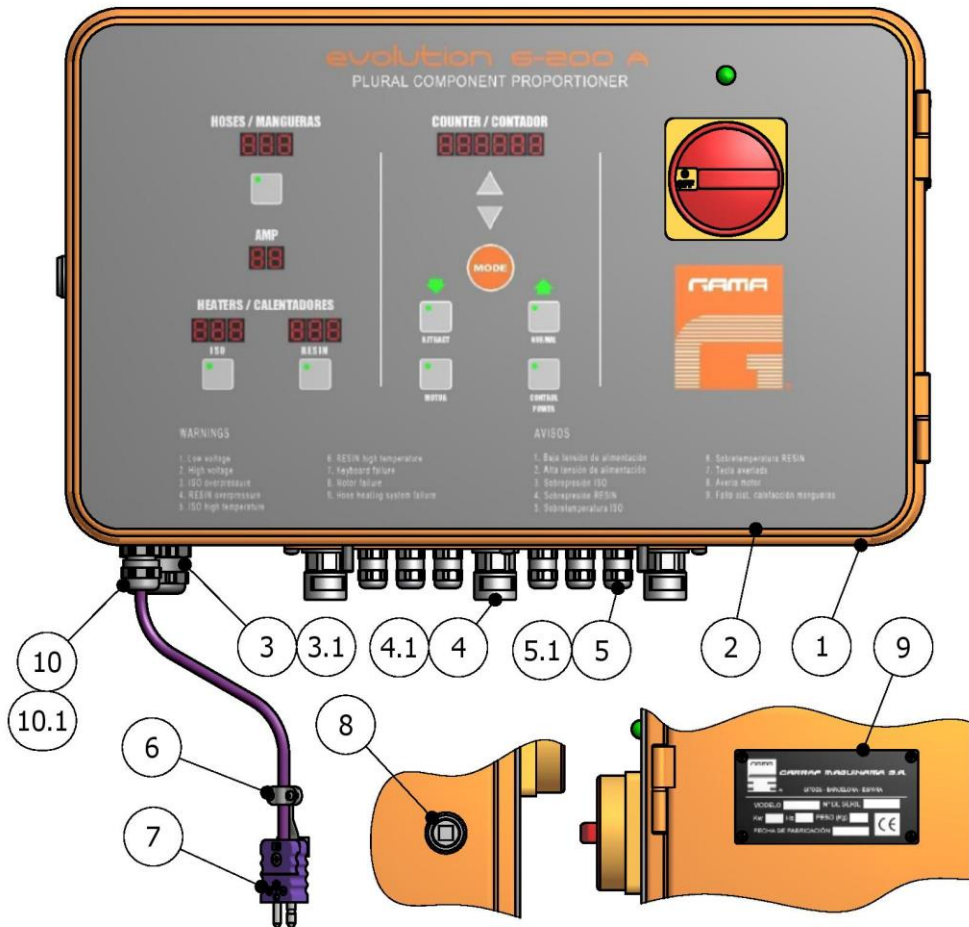

Figure 4. Electrical Console evolution G-200 A Model



Table 7. Electrical Console evolution G-200 A Model, Parts List

Ref.	Description	Part Number	Qty.
1	Electrical Console	EL-00027-01	1
2	Bezel & Electric Circuit Assembly	EL-00073-00	1
3	Cable Connector	EL-00088-01	1
3.1	Nut (not shown)	EL-00090-03	1
4	Strain Relief	EL-00087-00	3
4.1	Nut (not shown)	EL-00090-01	3
5	Strain Relief	EL-00088-00	6
5.1	Nut (not shown)	EL-00090-00	6
6	Connector Sensor Clamp	EL-00096-86	1
7	Male Connector Sensor	EL-00096-84	1
8	Lock Electrical Console	EL-00034	1
9	Standard Features Bezel	MQ-01010	1
10	Strain Relief	EL-00088-05	1
10.1	Nut (not shown)	EL-00090-06	1

GUIDE WHEELS SYSTEM

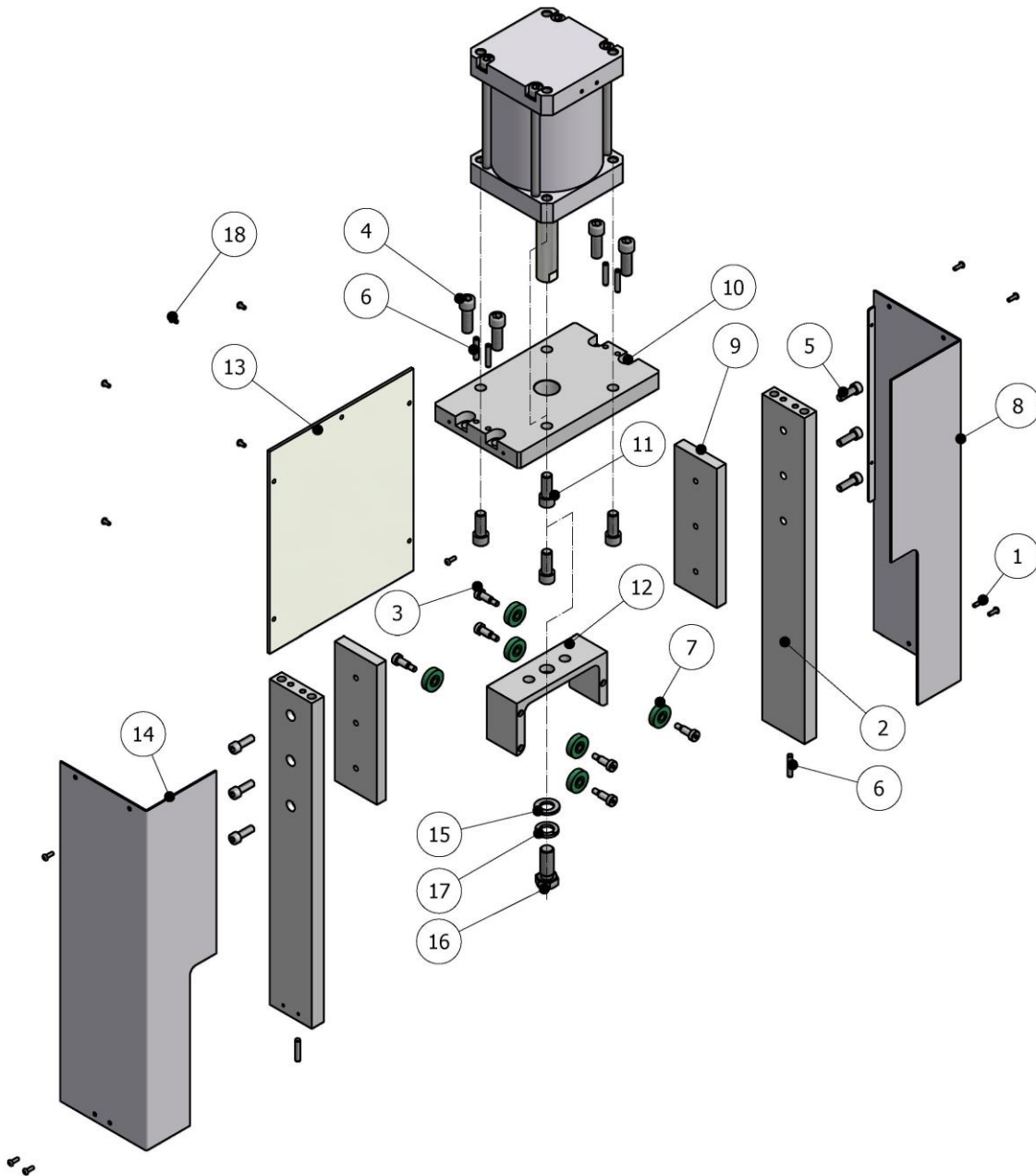

Figure 5. Guide Wheel System, Exploded View.

**Table 8. Guide Wheels System, Parts List**

Ref.	Description	Part Number	Qty.
1	Hex Head Cap Screw	TN-00324	8
2	Support Guide	PU-02000-15	2
3	Screw	TN-00057	6
4	Socket Head Cap Screw	TN-00053	4
	AET Washer	TN-00015	4
5	Socket Head Cap Screw	TN-00058	6
	AET Washer	TN-00038	6
6	Dowel Pin	TN-00055	6
7	Wheel	PU-02000-24	6
8	Cover	PU-02000-18	1
9	Wheel Support	PU-02000-25	2
10	Air Cylinder Support Plate	PU-02000-19A	1
11	Socket Head Cap Screw	TN-00043	4
	AET Washer	TN-00015	4
12	Puma Yoke	PU-02000-05A	1
13	Front Cover	PU-02000-16	1
14	Cover	PU-02000-17	1
15	Washer	TN-00045	1
16	Hex Head Cap Screw	TN-00095	1
17	Washer	TN-00044	1
18	Hex Head Cap Screw	TN-00502	5

CONNECTION PROPORTIONING PUMP

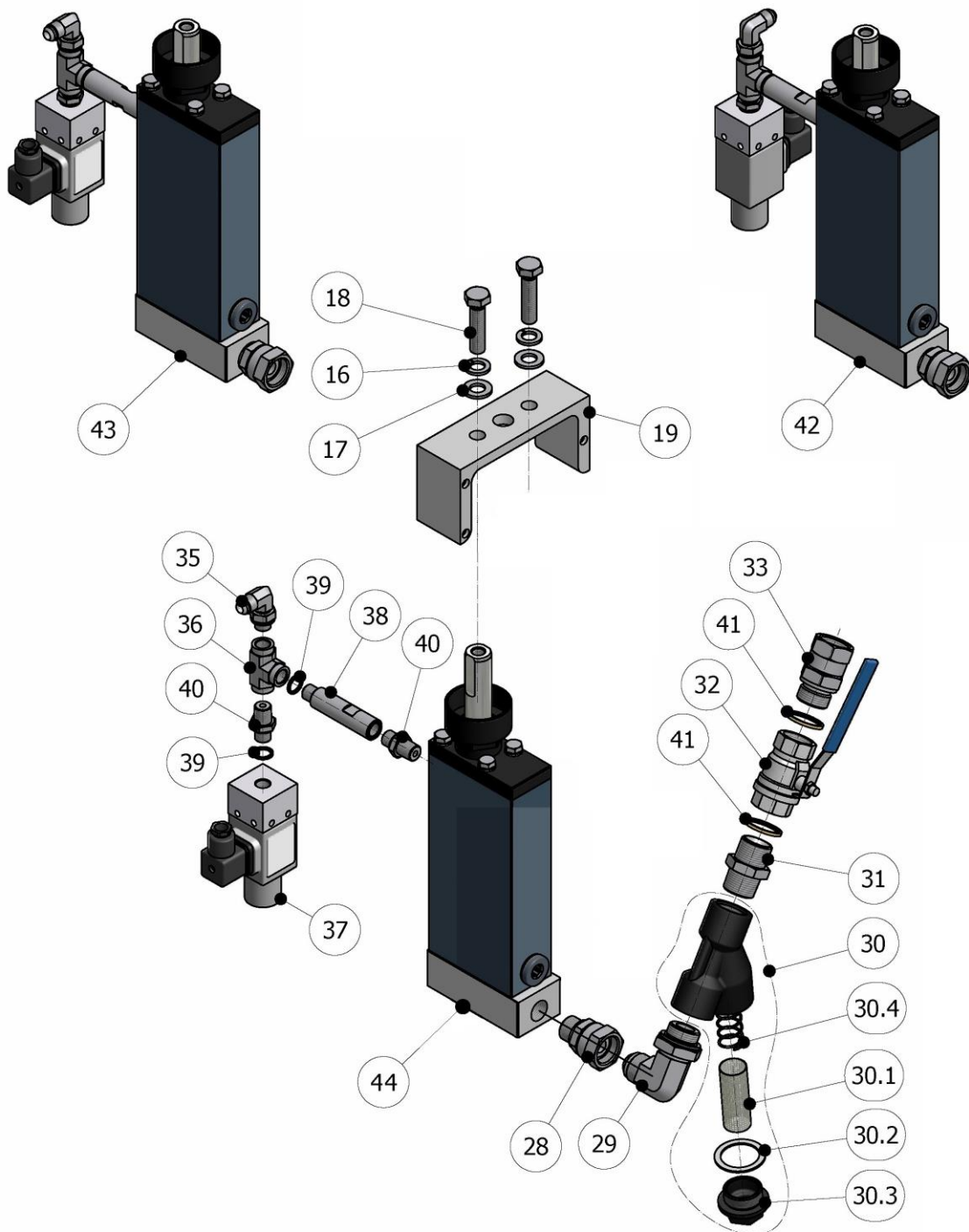

Figure 6. Connection Proportioning Pump, Exploded View



Table 9. Connection Proportioning Pump, Parts List

Ref.	Description	Part Number	Qty.
16	AET Washer	TN-00015	2
17	Washer	TN-00040	2
18	Socket Head Cap Screw	TN-00056	2
19	Puma Yoke	PU-02000-05A	1
28	Swivel Union	RA-00141	2
	Metal O-Ring	OR-00023	2
29	Elbow	RA-00072	2
30	Y-Strainer	RA-00074-00	2
30.1	Filter	RA-00074-03-30	2
30.2	Filter Gasket	OR-00061	2
30.3	Filter Plug	RA-00074-01	2
30.4	Spring	SP-00017	2
31	Hex Nipple	RA-00143	2
32	Ball Valve	RA-00078	2
33	Swivel Union	RA-00073	2
34			
35	Hose Elbow	RA-00050	2
36	Pipe Tee	RA-00053	2
37	Pressure Switch	See Table 10	-
38	Adapter	RA-00101	2
39	Seal	See Table 10	-
40	Hex Nipple	See Table 10	-
41	Seal	OR-00082	4
42	ISO Pump Assy	See Table 5	1
43	POL Pump Assy	See Table 5	1
44	Body Pump Assy (ISO & POL mutual pump)	See Table 12	2
45	Pressure Switch (See Figure 7)	See Table 10	-

Note: The indicated quantities are for a pair of pums.

Table 10. Optional Assemblies of the Pressure Switch, Parts List

Ref.	Description	Part Number	Qty. Option 1	Qty. Option 2
37	Pressure Switch	HI-00021	2	-
39	Seal Ring	OR-00054	4	4
40	Hex. Nipple	RA-00138	4	2
45	Pressure Switch	HI-00016	-	2

Option 1, is for all versions.

Option 2, is only for the version G-125 A #7.6 size pumps.

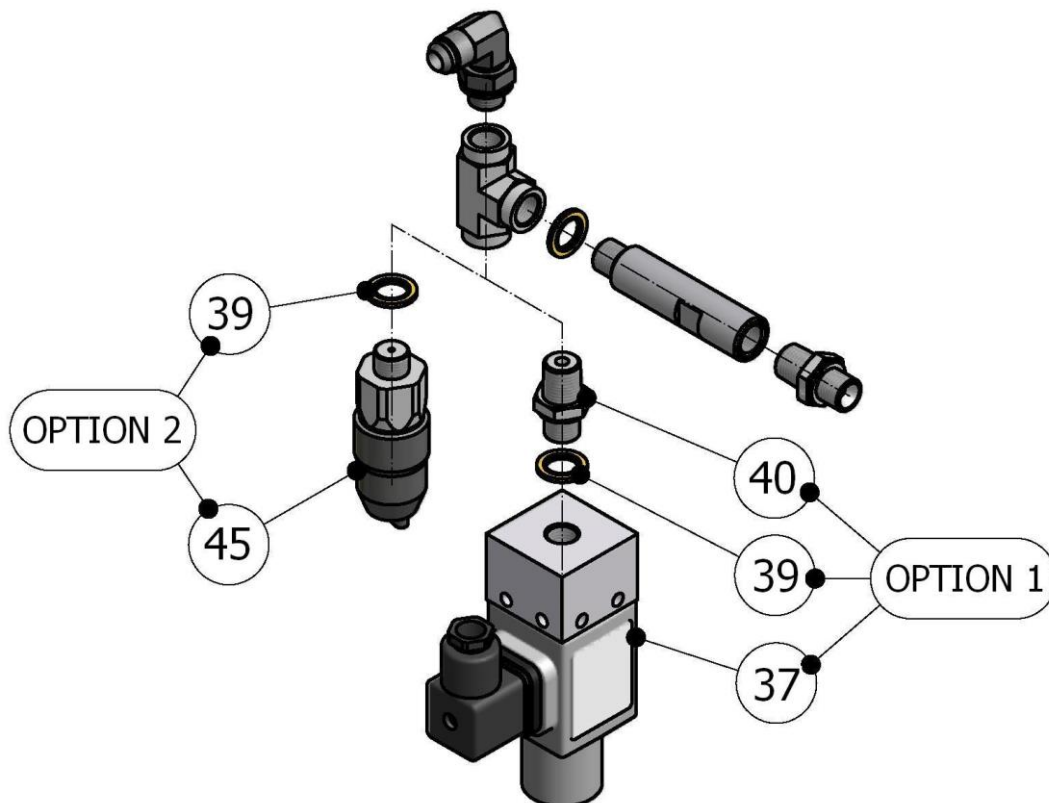

Figure 7. Options of Assembly of the Pressure Switches

PROPORTIONING PUMP

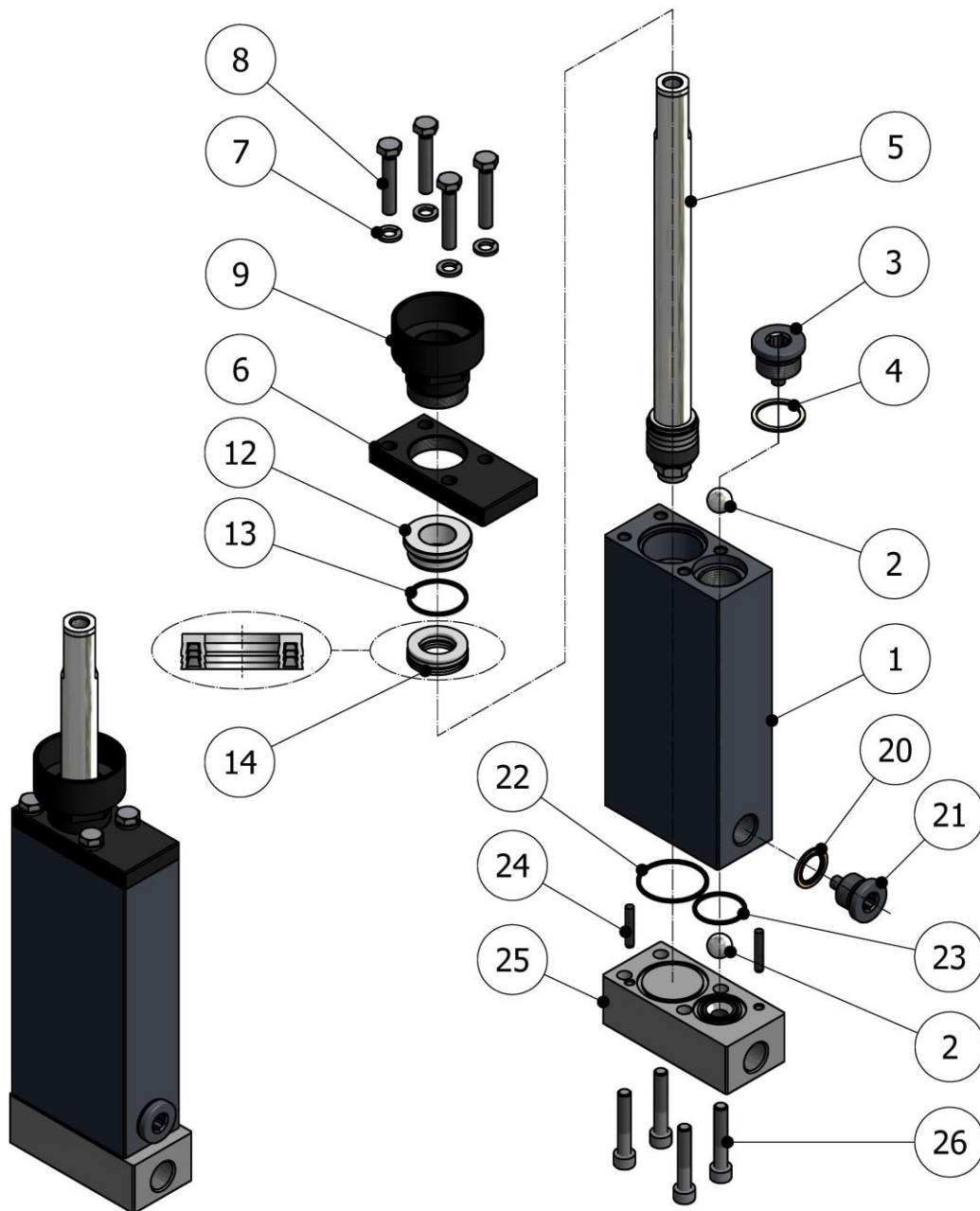

Figure 8. Product Pumps



Table 11. Proportioning Pump, Parts List

Ref.	Description	Part Number	Qty.
1	Pump Body With Check Valve Assembly	See Table 12	2
1.1	Pump Body	See Table 12	2
1.2	Check Valve Assembly	PU-02000-09	2
2	Valve Ball	TN-00012	4
3	Plug	PU-02000-21	2
4	Seal	PU-02000-27	2
5	Piston Rod Assembly	See Sheet 22	2
6	Packing Retainer	See Table 12	2
7	Lock Washer	TN-00028	8
8	Socket Head Cap Screw	TN-00051	8
9	Parking Nut W/Lube Cup	See Table 12	2
12	Bearing (▲)	See Table 12	2
13	O-Ring (▲)	See Table 12	2
14	Cylinder Seal (▲)	See Table 12	2
20	O-Ring	OR-00023	2
21	Plug	PU-02000-10	2
22	O-Ring	See Table 12	2
23	O-Ring	OR-00014	2
24	Dowel Pin	TN-00042	4
25	Pump Base With Check Valve Assembly	See Table 12	2
25.1	Check Valve Assembly	PU-02000-09	2
25.2	Base Plate	See Table 12	2
26	Socket Head Cap Screw	TN-00046	8
27	Dowel Pin (not indicated in Figure 6)	TN-00055	4

Note: The indicated quantities are for one pump.

(▲) Parts Included in Repair Seal Kit (see Table 15)

The Repair Seal Kit include the parts for 1 pump.



Table 12. Proportioning Pump evolution G-125 A, Variant SIZE, Parts List

item	(#)	(*)
	7.6 Size	4.5 Size
1	PU-02000-02A	PU-02001-02A
1.1	PU-02000-02	PU-02001-02
6	PU-02000-03	PU-02000-03
9	PU-02000-31	PU-02001-31
12 ▲	PU-02000-30G	PU-02001-30G
13 ▲	OR-00021	OR-00125
14 ▲	OR-00116G	OR-00117G
22	OR-00013	OR-00013
25	PU-02000-01A	PU-02000-01A
25.2	PU-02000-01	PU-02000-01

Note:

(#) The standard proportioning pump size for G-125 A is #7.6, (*) for G-200 A is #4.5. Different sizes are available under order. For delivery time, please consult with Marketing department.

(▲) Parts Included in Repair Seal Kit (see Table 15)

item	13.5 Size	11.8 Size	9.0 Size	7.2 Size	6.7 Size
1	PU-02014-02A	PU-02016-02A	PU-02012-02A	PU-02013-02A	PU-02006-02A
1.1	PU-02014-02	PU-02016-02	PU-02012-02	PU-02013-02	PU-02006-02
6	PU-02014-03	PU-02014-03	PU-02012-03	PU-02000-03	PU-02000-03
9	PU-02014-31	PU-02014-31	PU-02012-31	PU-02000-31	PU-02000-31
12 ▲	PU-02014-30G	PU-02016-30G	PU-02012-30G		PU-02006-30G
13 ▲	OR-00169	OR-00169	OR-00032		OR-00021
14 ▲	OR-00168G	OR-00183G	OR-00155G		OR-00174G
22	OR-00170	OR-00170	OR-00013	OR-00013	OR-00013
25	PU-02014-01A	PU-02014-01A	PU-02000-01A	PU-02000-01A	PU-02000-01A
25.2	PU-02014-01	PU-02014-01	PU-02000-01	PU-02000-01	PU-02000-01

(▲) Parts Included in Repair Seal Kit (see Table 15)



Parts Manual

item	6.3 Size	5.7 Size	5.1 Size	4.7 Size	3.2 Size
1	PU-02003-02A	PU-02002-02A	PU-02005-02A	PU-02009-02A	PU-02011-02A
1.1	PU-02003-02	PU-02002-02	PU-02005-02	PU-02009-02	PU-02011-02
6	PU-02000-03	PU-02000-03	PU-02000-03	PU-02000-03	PU-02000-03
9	PU-02000-31	PU-02000-31	PU-02000-31	PU-02001-31	PU-02001-31
12 ▲	PU-02003-30G				
13 ▲	OR-00021	OR-00021	OR-00021	OR-00125	OR-00125
14 ▲	OR-00179G				OR-00144
22	OR-00013	OR-00013	OR-00013	OR-00013	OR-00013
25	PU-02000-01A	PU-02000-01A	PU-02000-01A	PU-02000-01A	PU-02000-01A
25.2	PU-02000-01	PU-02000-01	PU-02000-01	PU-02000-01	PU-02000-01

item					2.9 Size
1					PU-02015-02A
1.1					PU-02015-02
6					PU-02000-03
9					PU-02001-31
12 ▲					PU-02015-30G
13 ▲					OR-00125
14 ▲					OR-00173G
22					OR-00013
25					PU-02000-01A
25.2					PU-02000-01

(▲) Parts Included in Repair Seal Kit (see Table 15)

PISTON ROD ASSEMBLY

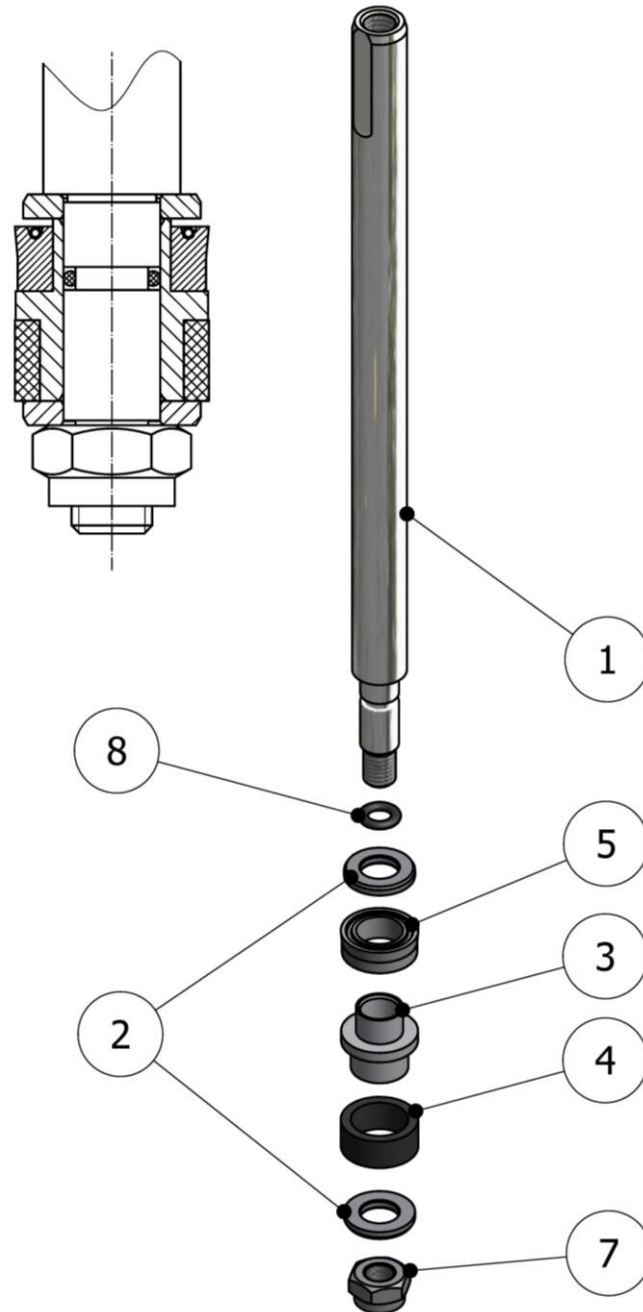

Figure 9. Piston Rod Assembly, Exploded View



Table 13. Piston Rod Assembly, Parts List

Ref.	Description	Part Number	Qty.
1	Pump Piston Rod	See Table 14	1
2	Washer	See Table 14	2
3	Piston Seal Support	See Table 14	1
4	Piston Seal (▲)	See Table 14	1
5	O-Ring (▲)	See Table 14	2
6			
7	Nut	See Table 14	1
8	O-Ring (▲)	See Table 14	1

(▲) Parts Included in Repair Seal Kit (see Table 15)

The Repair Seal Kit include the parts for 1 pump.



Table 14. Piston Rod Size, Parts List

Pump Size	item 1	item 2	item 3	item 4 ▲
13.5	PU-02014-06	PU-02014-08	PU-02014-07R	OR-00167
11.8	PU-02016-06	PU-02016-08	PU-02016-07R	OR-00182
9.0	PU-02012-06	PU-02012-08	PU-02012-07R	OR-00154
7.6 (#)	PU-02000-06	PU-02000-08	PU-02000-07R	OR-00016
7.2	PU-02013-06	PU-02013-08	PU-02013-07R	OR-00162
6.7	PU-02006-06	PU-02006-08	PU-02006-07R	OR-00086
6.3	PU-02003-06	PU-02003-08	PU-02003-07R	OR-00078
5.7	PU-02002-06	PU-02002-08	PU-02002-07R	OR-00059
5.1	PU-02005-06	PU-02005-08	PU-02005-07R	OR-00080
4.7	PU-02009-06	PU-02009-08	PU-02009-07R	OR-00105
4.5 (*)	PU-02001-06	PU-02001-08	PU-02001-07R	OR-00050
3.2	PU-02011-06	PU-02010-08	PU-02010-07R	OR-00145
2.9	PU-02015-06	PU-02015-08	PU-02015-07R	OR-00172

Pump Size	item 5 ▲	item 6	item 7	item 8 ▲
13.5	OR-00166		TN-00342	OR-00011
11.8	OR-00184		TN-00342	OR-00011
9.0	OR-00152		TN-00030	OR-00015
7.6 (#)	OR-00156		TN-00030	OR-00015
7.2	OR-00161		TN-00030	OR-00015
6.7	OR-00175		TN-00165	OR-00049
6.3	OR-00180		TN-00165	OR-00049
5.7			TN-00165	OR-00049
5.1			TN-00165	OR-00049
4.7			TN-00165	OR-00049
4.5 (*)	OR-00151		TN-00165	OR-00049
3.2			TN-00283	OR-00024
2.9	OR-00171		TN-00283	OR-00024

Note: (#) The standard proportioning pump size for G-125 A is #7.6, (*) for G-200 A is #4.5. Different sizes are available under order. For delivery time, please consult with Marketing department.

(▲) Parts Included in Repair Seal Kit (see Table 15)



Table 15. Repair Seals Kit, Parts List

KIT SEALS REF.	From pg.18			From pg.22		
	POS. 12	POS. 13	POS. 14	POS. 4	POS. 5	POS. 8
KT-00166 (2.9)	PU-02015-30G	OR-00125	OR-00173G	OR-00172	OR-00171	OR-00024
- (3.2)	-	OR-00125	-	OR-00145	-	OR-00024
KT-00153 (#4.5)	PU-02001-30G	OR-00125	OR-00117G	OR-00050	OR-00151	OR-00049
- (4.7)	PU-02009-30	OR-00125	-	OR-00105	-	OR-00049
- (5.1)	PU-02005-30	OR-00021	-	OR-00080	-	OR-00049
- (5.7)	PU-02002-30	OR-00021	-	OR-00059	-	OR-00049
KT-00185 (6.3)	PU-02003-30G	OR-00021	OR-00179G	OR-00078	OR-00180	OR-00049
KT-00176 (6.7)	PU-02006-30G	OR-00021	OR-00174G	OR-00086	OR-00175	OR-00049
- (7.2)	-	-	-	OR-00162	OR-00161	OR-00015
KT-00129 (*7.6)	PU-02000-30G	OR-00021	OR-00116G	OR-00016	OR-00156	OR-00015
KT-00203 (9.0)	PU-02012-30G	OR-00032	OR-00155G	OR-00154	OR-00152	OR-00015
KT-00187 (11.8)	PU-02016-30G	OR-00169	OR-00183G	OR-00182	OR-00184	OR-00011
KT-00164 (13.5)	PU-02014-03G	OR-00169	OR-00168G	OR-00167	OR-00166	OR-00011

Note: (#) The standard proportioning pump size for G-125 A is #7.6, (*) for G-200 A is #4.5. Different sizes are available under order. For delivery time, please consult with Marketing department.

AIR CONTROL ASSEMBLY

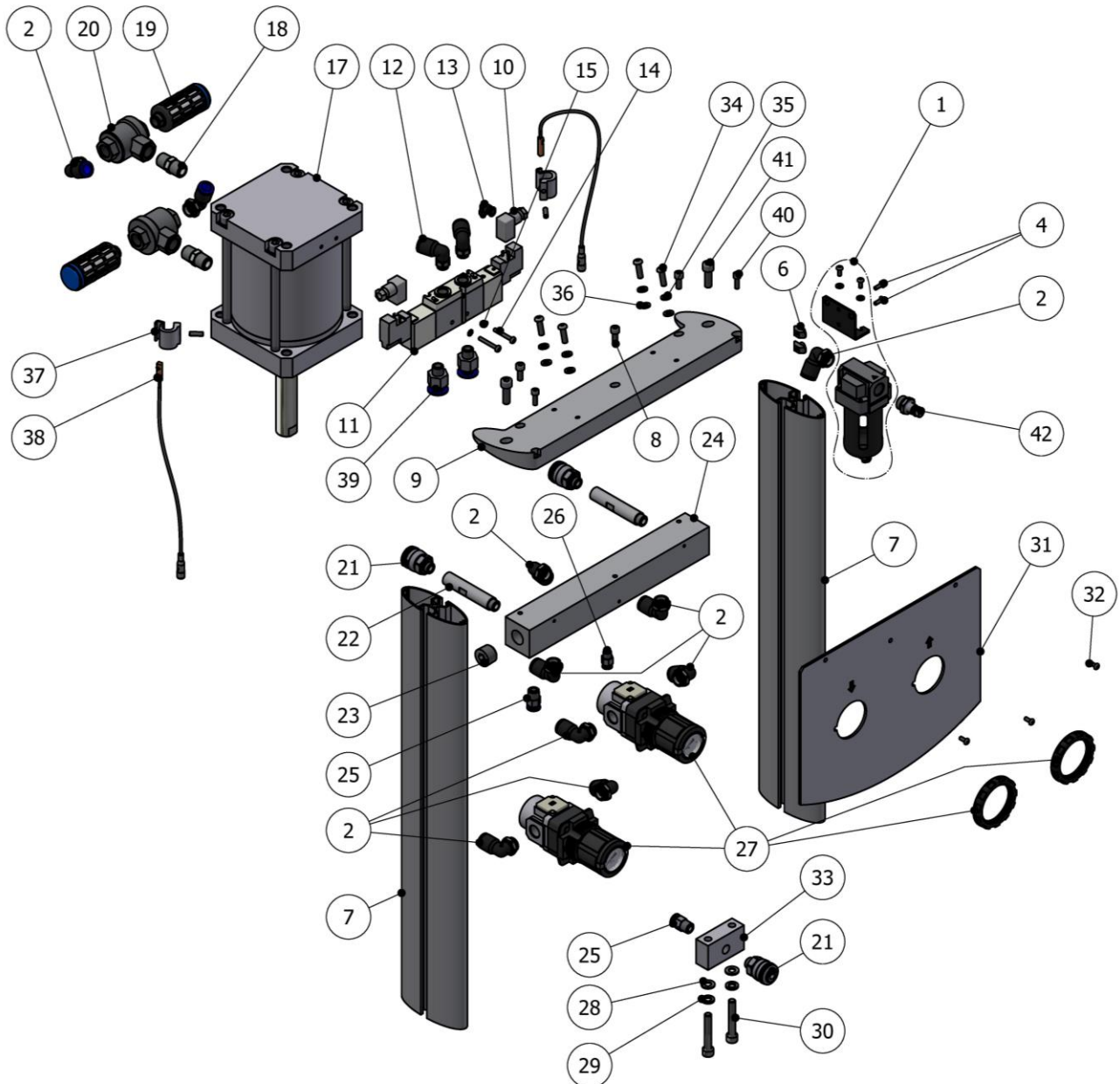

Figure 10. Air Control Assembly, Exploded View



Table 16. Air Control Assembly, Parts List

Ref.	Description	Part Number	Qty.
1	Air Filter Assy (with drilled bracket & screws)	NE-00064	1
2	Tube Fitting	RA-00085	10
3			
4	Allen Screw	TN-00049	2
5			
6	Nut	TN-00094	2
7	Electric Console Support	MQ-02003	2
8	Socket Head Cap Screw	TN-00061	3
9	Electric Console Support Plate	MQ-02002B	1
10	Connector	NE-00013	2 (*)
11	Directional Valve	NE-00065	1
12	Tube Fitting	RA-00046	2
13	Tube Fitting	RA-00088	1
14	Screw	TN-00294	2
15	Washer	TN-00104	2
16			
17	Air Motor	NE-00059	1
18	Male Union	RA-00054	2
19	Muffler	NE-00056	2
20	Exhaust Valve	NE-00060	2
21	Fast Socket	RA-00095	3
22	Swivel Union	RA-00101	2
23	Plug	RA-00103	1
24	Air Manifold	MQ-02004	1
25	Tube Fitting	RA-00150	2
26	Tube Fitting	RA-00206	1
27	Pressure Regulator	NE-00063	2
28	Washer	TN-00119	2
29			
30	Screw	TN-00051	2



Ref.	Description	Part Number	Qty.
31	Control Panel	MQ-02021	1
32	Screw	TN-00031	2
33	Air Connection Support	MQ-02005	1
34	Screw	TN-00026	4
35	Washer	TN-00025	4
36	Washer	TN-00024	4
37	Magnetic switch support	NE-00061	2
38	Magnetic Switch	EL-00136-08	2
39	Tube Fitting	RA-00086	2
40	Screw	TN-00016	2
41	Screw	TN-00027	2
42	Coupler Plug	RA-00096	1

N.B.:

The Parts indicated (*) are included in Ref. 11

Table 17. Pneumatic Tubes List, G-125/200 A Model

Ref.	Description	Part Number	Qty.
	Blue Tube PA Ø12xØ10	MA-00069	
	Blue Tube PA Ø8xØ6	MA-00072	
	Blue Tube PA Ø6xØ4	MA-00071	

(*) Raw Material Reference.



AIR MOTOR ASSEMBLY



Figura 11. Air Motor, Exploded view

**Table 18. Air Motor Assembly, Parts List**

Ref.	Description	Part Number	Qty.
1	Front Block	NE-00059-01	1
2	Rear Block	NE-00059-02	1
3	Cylinder Body	NE-00059-03	1
4	Piston Rod	NE-00059-04	1
5	Magnetic Piston Assy	NE-00059-05	1
5.1	Piston	NE-00059-06	1 (*)
5.2	Magnet	NE-00059-07	1 (*)
5.3	Piston Guide	OR-00100	1 (*)
5.4	Piston Seal	OR-00101	1 (*)
5.5	O-Ring	OR-00103	1 (*)
6	O-Ring	OR-00102	2
7	Non Extrusion Ring	OR-00099	2
8	O-Ring	OR-00104	1
9	Guide Rod	TN-00288	1
10	Washer	TN-00291	1
11	Nut	TN-00290	1
12	AET Washer	TN-00145	4
13	ALLEN Screw	TN-00289	4

N.B.:

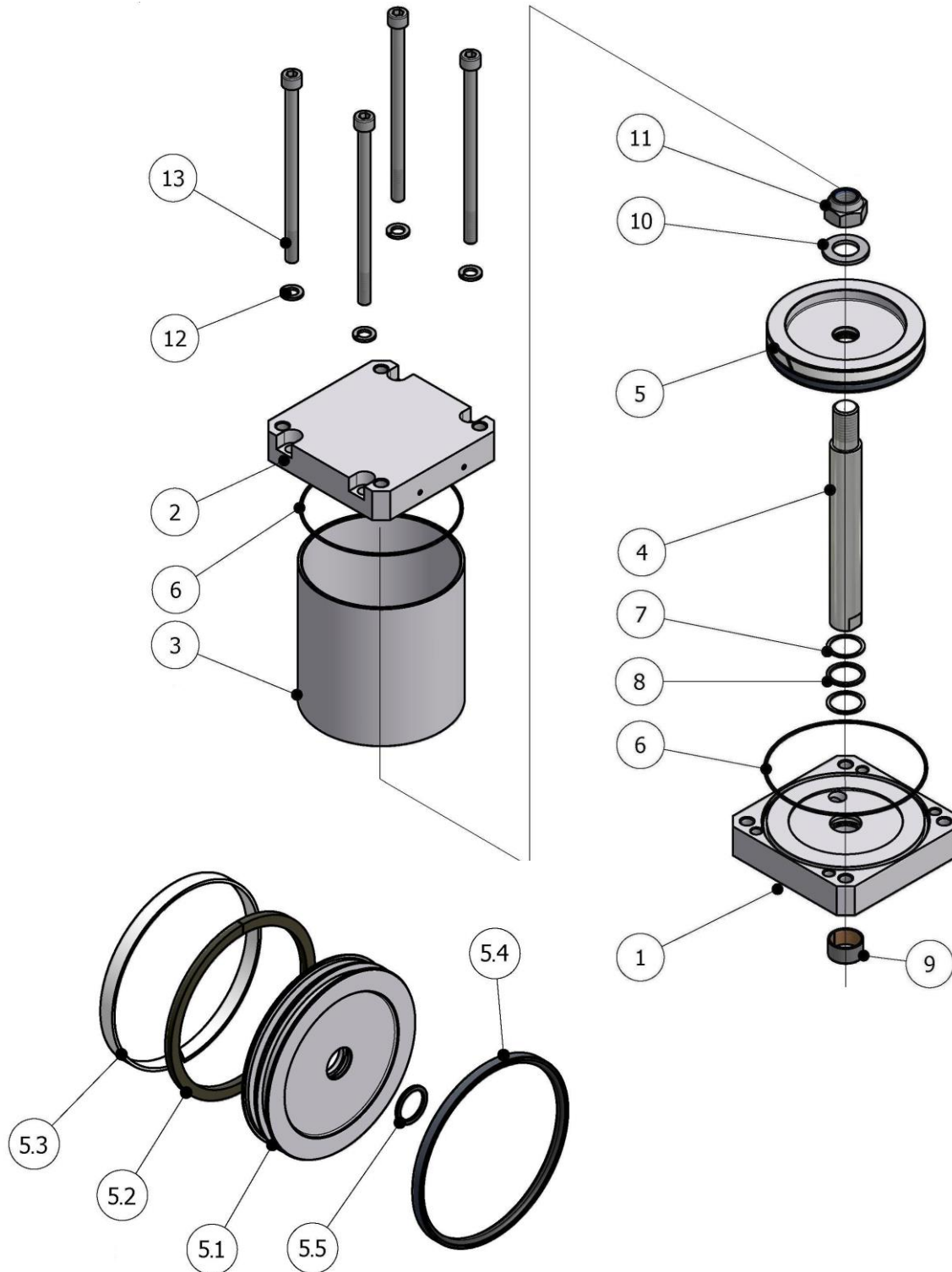
The Parts indicated (*) are included in Ref. 5

“A” PRIMARY HEATER

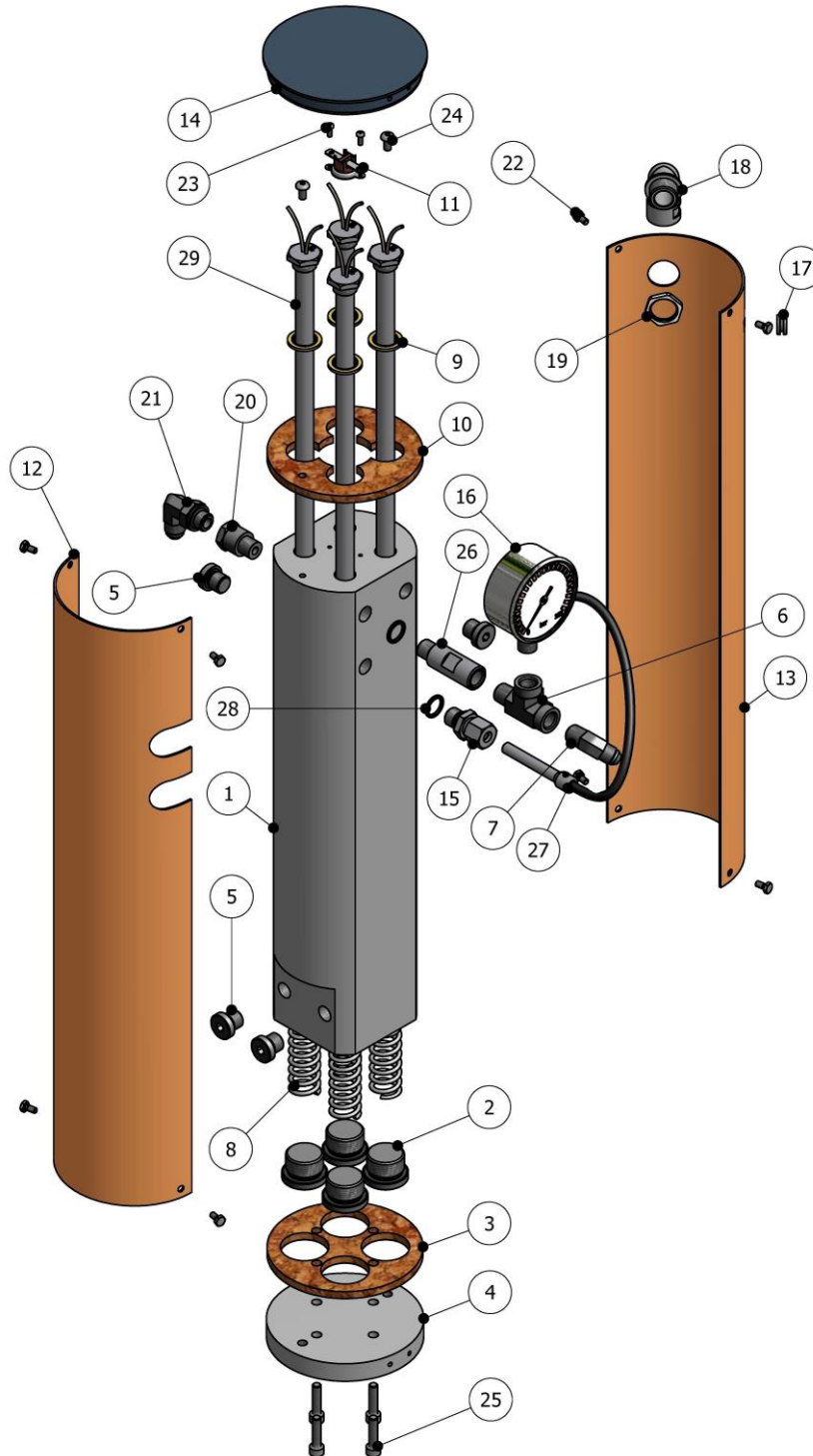

Figure 12. “A” Primary Heater, Exploded View



Table 19. A" Primary Heater, Parts List

Ref.	Description	Part Number	Qty.
1	Heat Block	CLH-02001-01A	1
2	Pipe Plug	RA-00012	4
3	Bottom Insulate Plate	CL-02001-03	1
4	Bottom Cap	CL-02001-02	1
5	Pipe Plug	RA-00013	4
6	Pipe Tee	RA-00018	1
7	Hose Nipple	RA-00017	1
8	Spring	SP-00009	4
9	Seal	OR-00018	4
10	Top Insulate Plate	CL-02001-04	1
11	Thermal Limit Switch	EL-00006	1
12	Heater Cover	CL-02001-06	1
13	Heater Cover	CL-02001-05	1
14	Top Cap	CL-02001-07	1
15	Thermocouple Nipple	RA-00231	1
16	Liquid Fill Gauge	See Table 20	1
17	Rubber Grommet	EL-00095-00	1
18	Conduit Connector	EL-00087-01	1
19	Nut	EL-00090-01	1
20	Swivel Union	RA-00077	1
21	Hose Nipple	RA-00050	1
22	Screw	TN-00502	8
23	Screw	TN-00128	2
24	Screw	TN-00221	2
25	Socket Head Cap Screw	TN-00169	4
26	Adapter	RA-00100	1
27	Thermocouple	EL-00146-00	1
28	Metal Seal	OR-00054	2
29	Heat Resistance	See Table 20	4
30			



Table 20. Parts List for each model of A-Heater

Part Number	Description	Ref. 16	Ref. 29
CLH-02001-00A	A-Primary Heater 5000 W	HI-00015	EL-00004
CLH-02001-00B	A-Primary Heater 6000 W	HI-00019	EL-00082
CLH-02001-00C	A-Primary Heater 5000 W	HI-00019	EL-00004

“R” PRIMARY HEATER

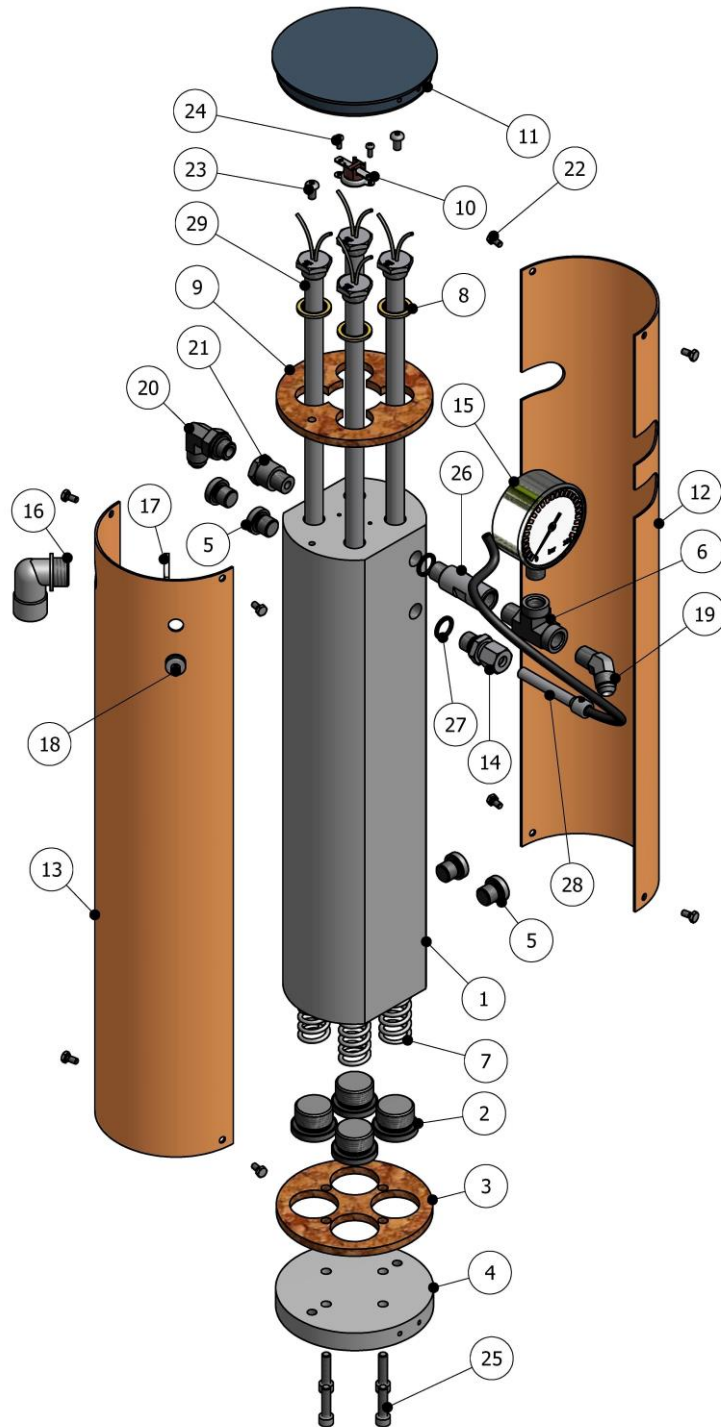

Figure 13. “R” Primary Heater, Exploded View



Table 21. “R” Primary Heater, Parts List

Ref.	Description	Part Number	Qty.
1	Heat Block	CLH-02001-01A	1
2	Pipe Plug	RA-00012	4
3	Bottom Insulate Plate	CL-02001-03	1
4	Bottom Cap	CL-02001-02	1
5	Pipe Plug	RA-00013	4
6	Pipe Tee	RA-00018	1
7	Spring	SP-00009	4
8	Seal	OR-00018	4
9	Top Insulate Plate	CL-02001-04	1
10	Thermal Limit Switch	EL-00006	1
11	Top Cap	CL-02001-07	1
12	Heater Cover	CL-02002-06	1
13	Heater Cover	CL-02002-05	1
14	Thermocouple Nipple	RA-00231	1
15	Liquid Fill Gauge	See Table 22	1
16	Conduit Connector	EL-00087-01	1
17	Nut	EL-00090-01	1
18	Rubber Grommet	EL-00095-00	1
19	Hose Nipple	RA-00043	1
20	Hose Nipple	RA-00050	1
21	Swivel Union	RA-00077	1
22	Screw	TN-00502	8
23	Screw	TN-00221	2
24	Screw	TN-00128	2
25	Socket Head Cap Screw	TN-00169	4
26	Adapter	RA-00100	1
27	Metal Seal	OR-00054	2
28	Thermocouple	EL-00146-00	1
29	Heat Resistance	See Table 22	4
30			



Table 22. Parts List for each model of R-Heater

Part Number	Description	Ref. 15	Ref 29
CLH-02002-00A	A-Primary Heater 5000 W	HI-00015	EL-00004
CLH-02002-00B	A-Primary Heater 6000 W	HI-00019	EL-00082
CLH-02002-00C	A-Primary Heater 5000 W	HI-00019	EL-00004



RECIRCULATION KIT P#: KT-00038

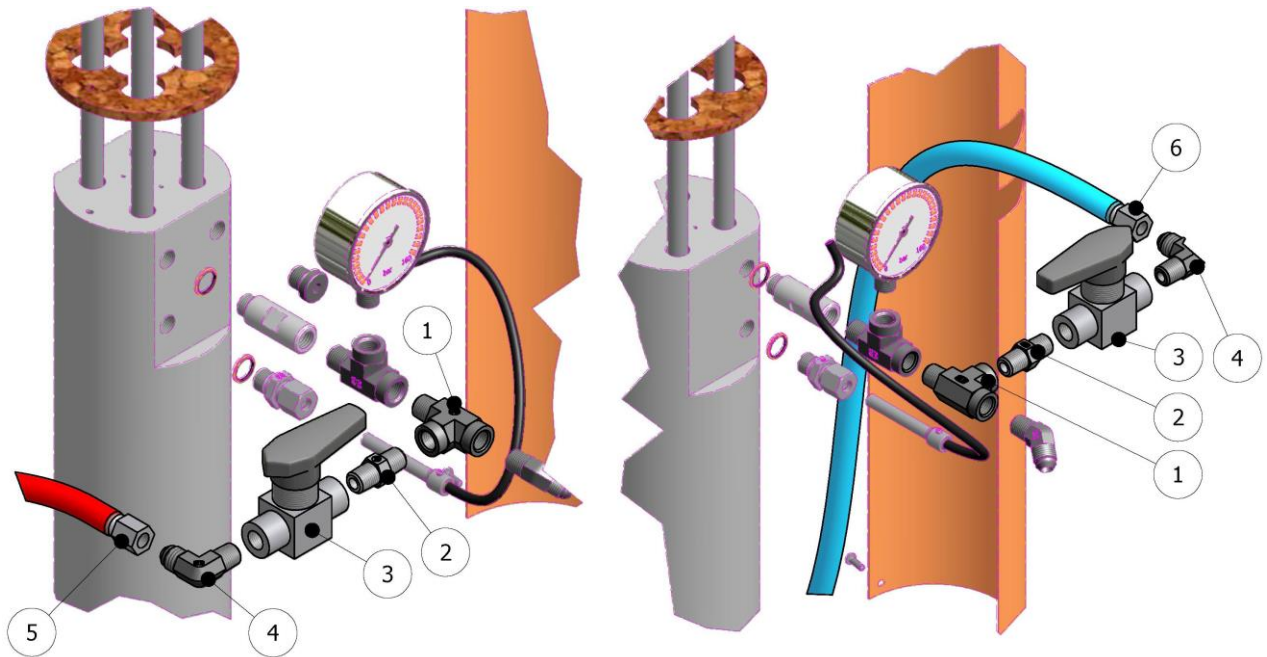

Figure 14. Recirculation Kit P#: KT-00038, Exploded View

Table 23. Recirculation Kit evolution, Parts List

Ref.	Description	Part Number	Qty.
1	Pipe Tee	RA-00018	2
2	Swivel Union	RA-00188	2
3	Ball Valve	RA-00217	2
4	Elbow ISO	RA-00254	1
	Elbow POL	RA-00044	1
5	A-Hose	MA-00050-01	1
6	R-Hose	MA-00050-00	1

RECIRCULATION KIT P#: KT-00038-01

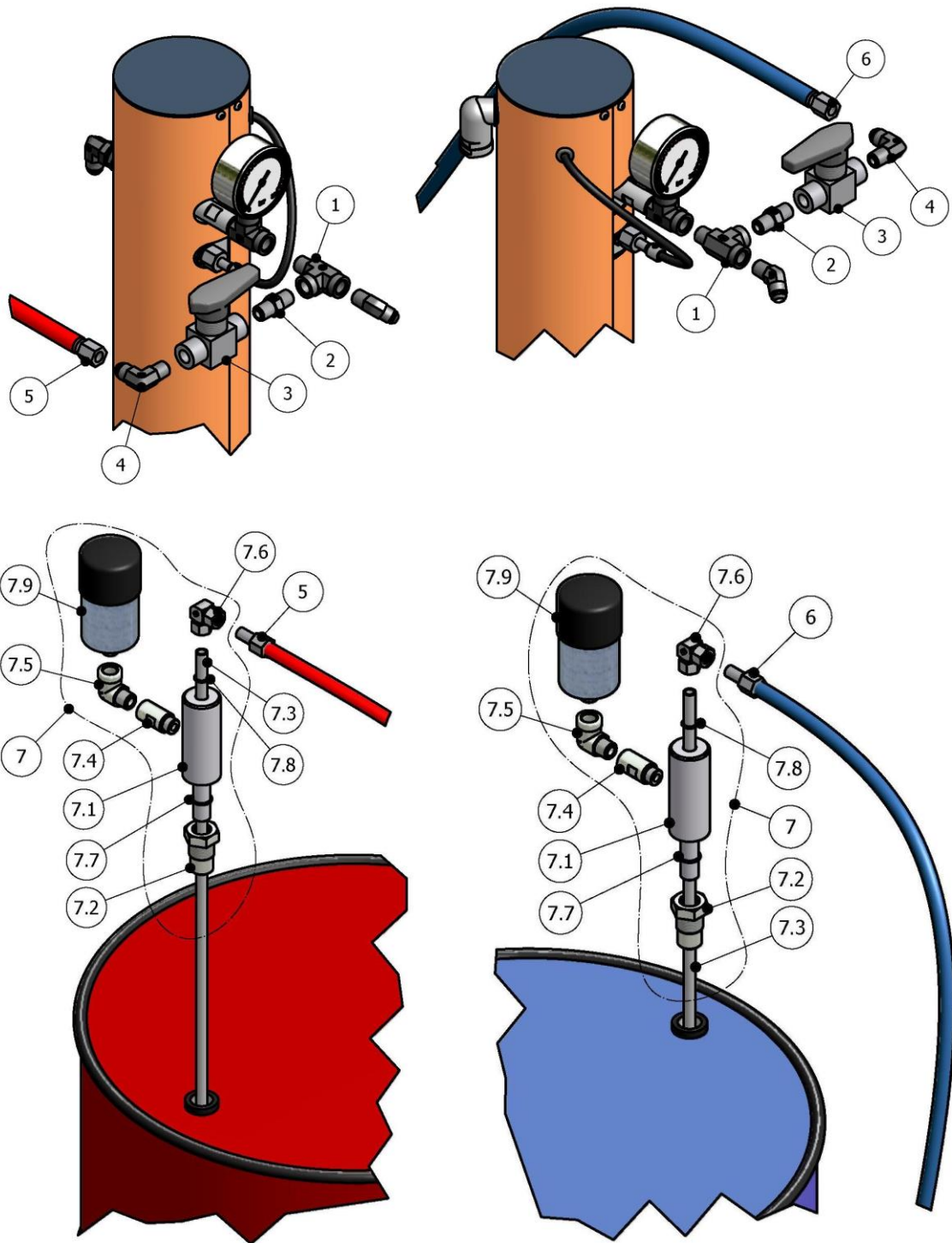

Figure 15. Recirculation Kit P#: KT-00038-01, Exploded View



**Table 24. Recirculation Kit evolution, Parts List
KT-00038-01**

Ref.	Description	Part -Number	Qty.
1	Pipe Tee	RA-00018	2
2	Swivel Union	RA-00188	2
3	Ball Valve	RA-00217	2
4	Elbow ISO	RA-00254	1
	Elbow POL	RA-00044	1
5	A-Hose	MA-00050-01	1
6	R-Hose	MA-00050-00	1
7	Assy. Connection to Tank	MQ-05009-00	2
7.1	Body connection	MQ-05010	1 (*)
7.2	Connection tank	MQ-05009	1 (*)
7.3	Pipe	HI-00075	1 (*)
7.4	Extension	RA-00256	1 (*)
7.5	Elbow	RA-00257	1 (*)
7.6	Elbow for Pipe	RA-00200	1 (*)
7.7	O-Ring	OR-00055	2 (*)
7.8	O-Ring	OR-00011	1 (*)
7.9	Dehumidifier filter	NE-00045	1 (*)

N.B.:

(*) Unitary Quantities included in 1 set Ref.7

RECIRCULATION KIT P#: KT-00038-03

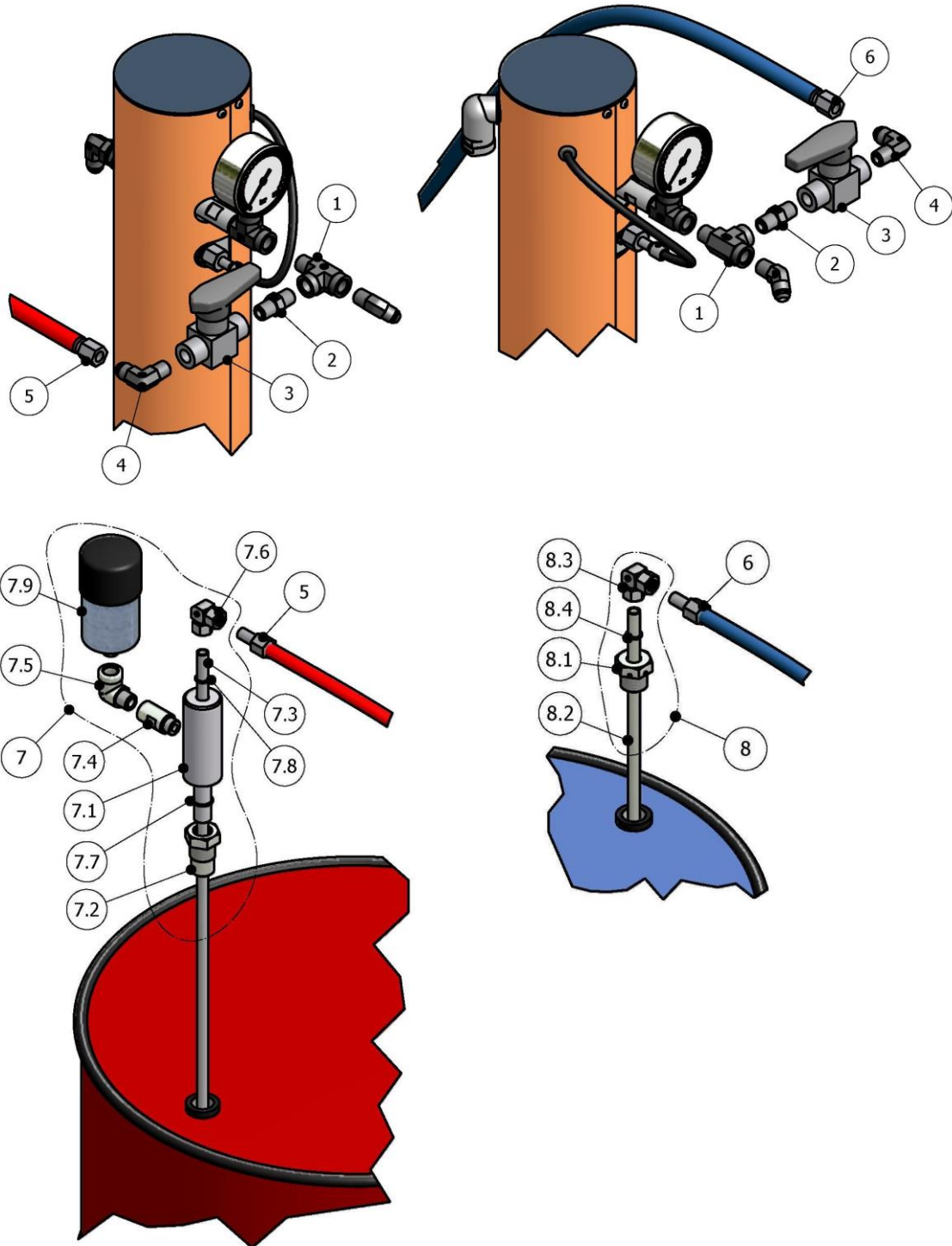

Figure 16. Recirculation Kit P#: KT-00038-03, Exploded View



**Table 25. Recirculation Kit evolution, Parts List
KT-00038-03**

Ref.	Description	Part –Number	Qty.
1	Pipe Tee	RA-00018	2
2	Swivel Union	RA-00188	2
3	Ball Valve	RA-00217	2
4	Elbow ISO	RA-00254	1
	Elbow POL	RA-00044	1
5	A-Hose	MA-00050-01	1
6	R-Hose	MA-00050-00	1
7	Assy. Connection to Tank with Filter	MQ-05009-00	1
7.1	Body connection	MQ-05010	1 (*)
7.2	Connection tank	MQ-05009	1 (*)
7.3	Pipe	HI-00075	1 (*)
7.4	Extension	RA-00256	1 (*)
7.5	Elbow	RA-00257	1 (*)
7.6	Elbow for Pipe	RA-00200	1 (*)
7.7	O-Ring	OR-00055	2 (*)
7.8	O-Ring	OR-00011	1 (*)
7.9	Dehumidifier filter	NE-00045	1 (*)
8	Assy. Connection to Tank without Filter	MQ-05010-00	1
8.1	Connection tank	MQ-05009-A	1 (#)
8.2	Pipe	HI-00075	1 (#)
8.3	Elbow for Pipe	RA-00200	1 (#)
8.4	O-Ring	OR-00011	1 (#)

N.B.:

(*) Unitary Quantities included in 1 set Ref.7

(#) Unitary Quantities included in 1 set Ref.8

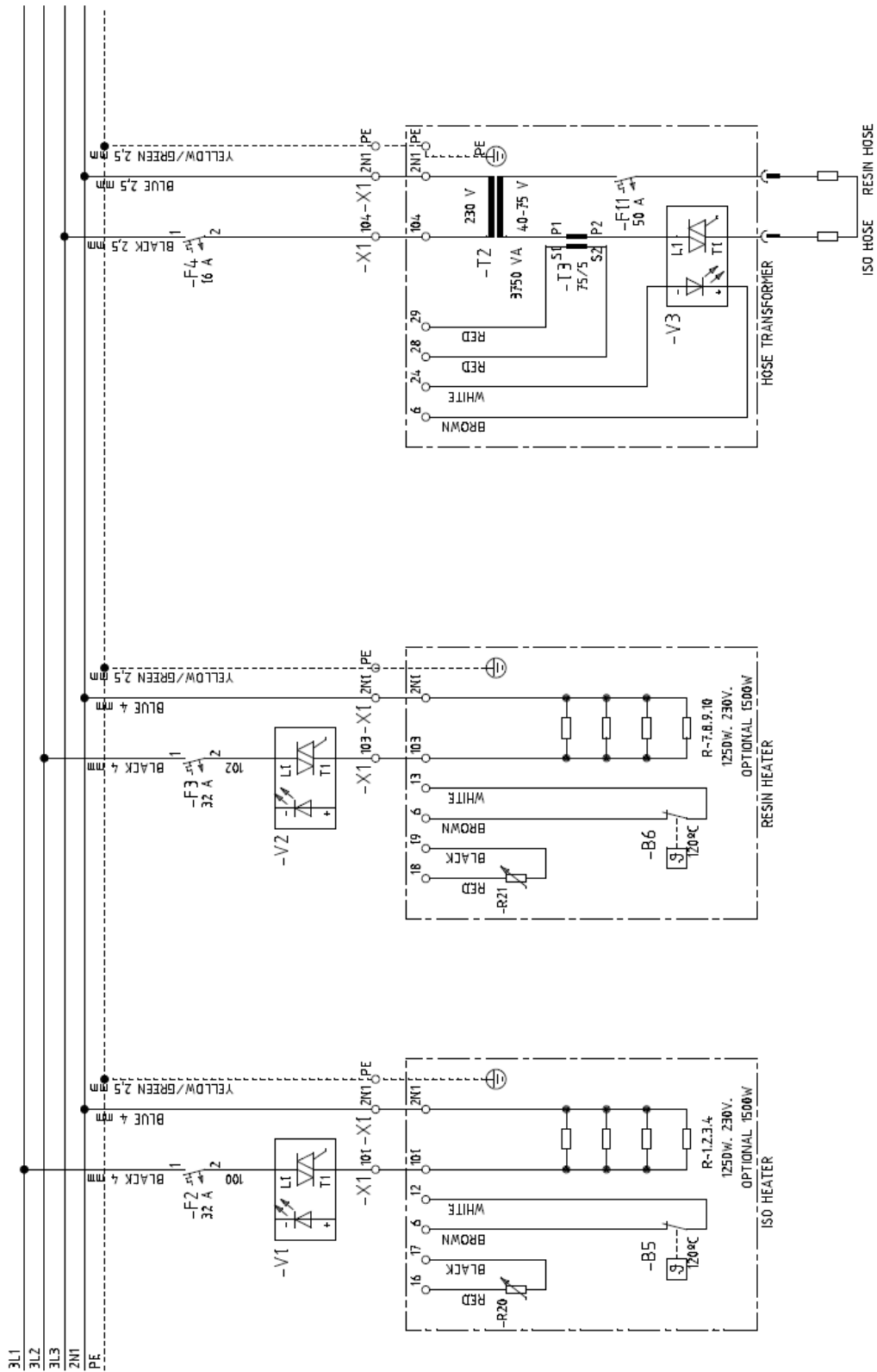

Figure 18. Electrical Schematic Diagram 3NPE~400V 50/60 Hz, Sheet 2 of 9

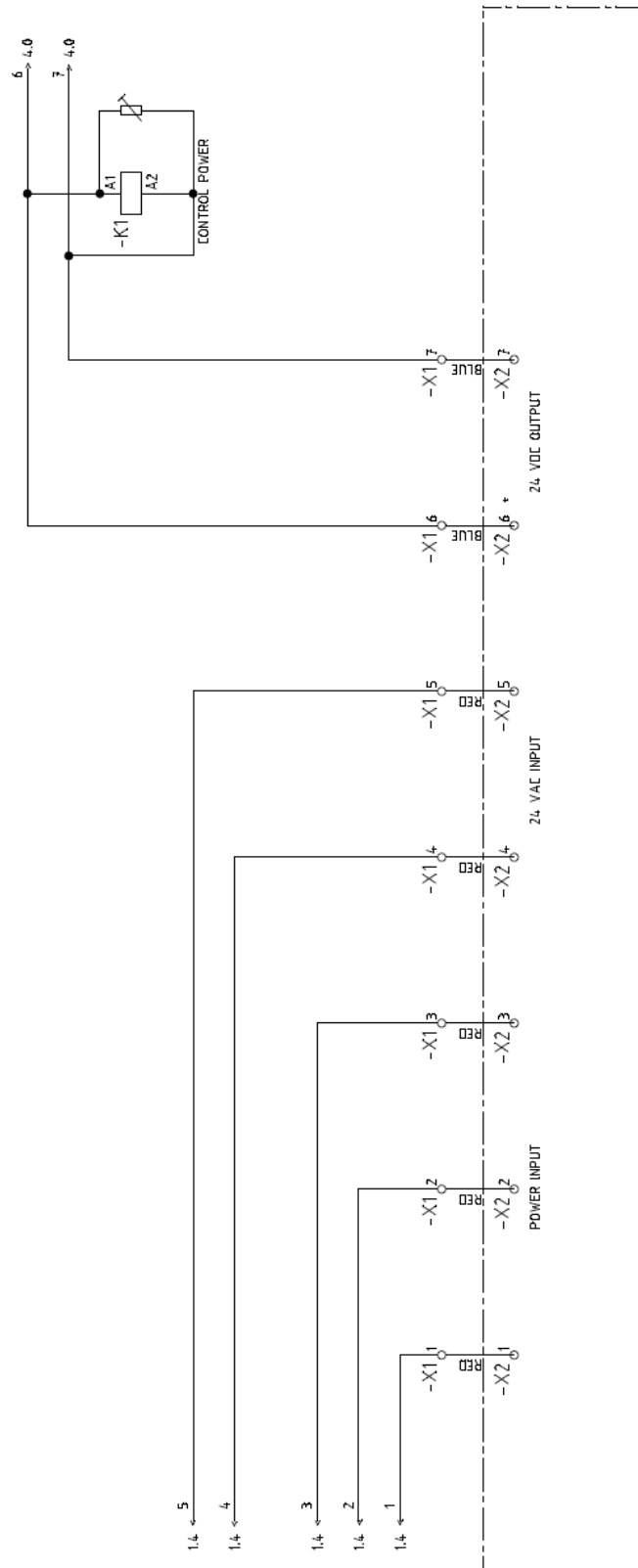

Figure 19. Electrical Schematic Diagram 3NPE~400V 50/60 Hz, Sheet 3 of 9

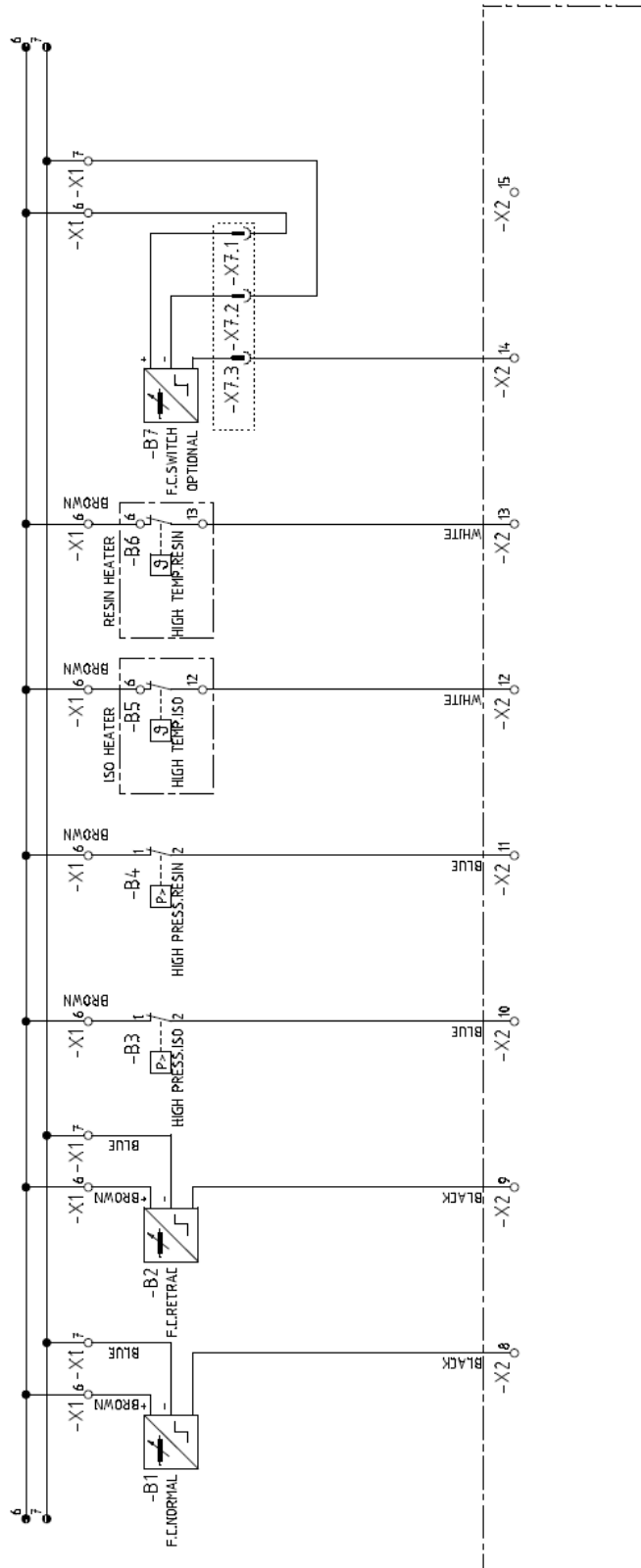

Figure 20. Electrical Schematic Diagram 3NPE~400V 50/60 Hz, Sheet 4 of 9

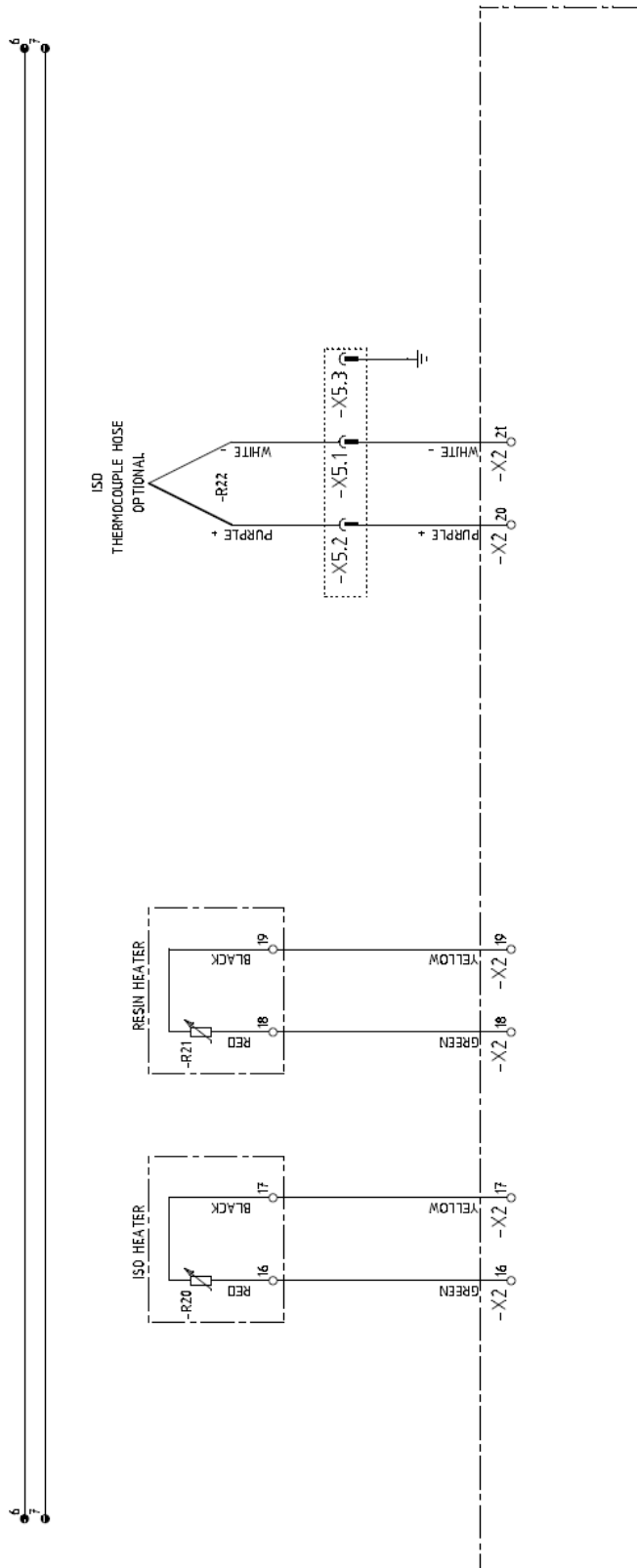

Figure 21. Electrical Schematic Diagram 3NPE~400V 50/60 Hz, Sheet 5 of 9

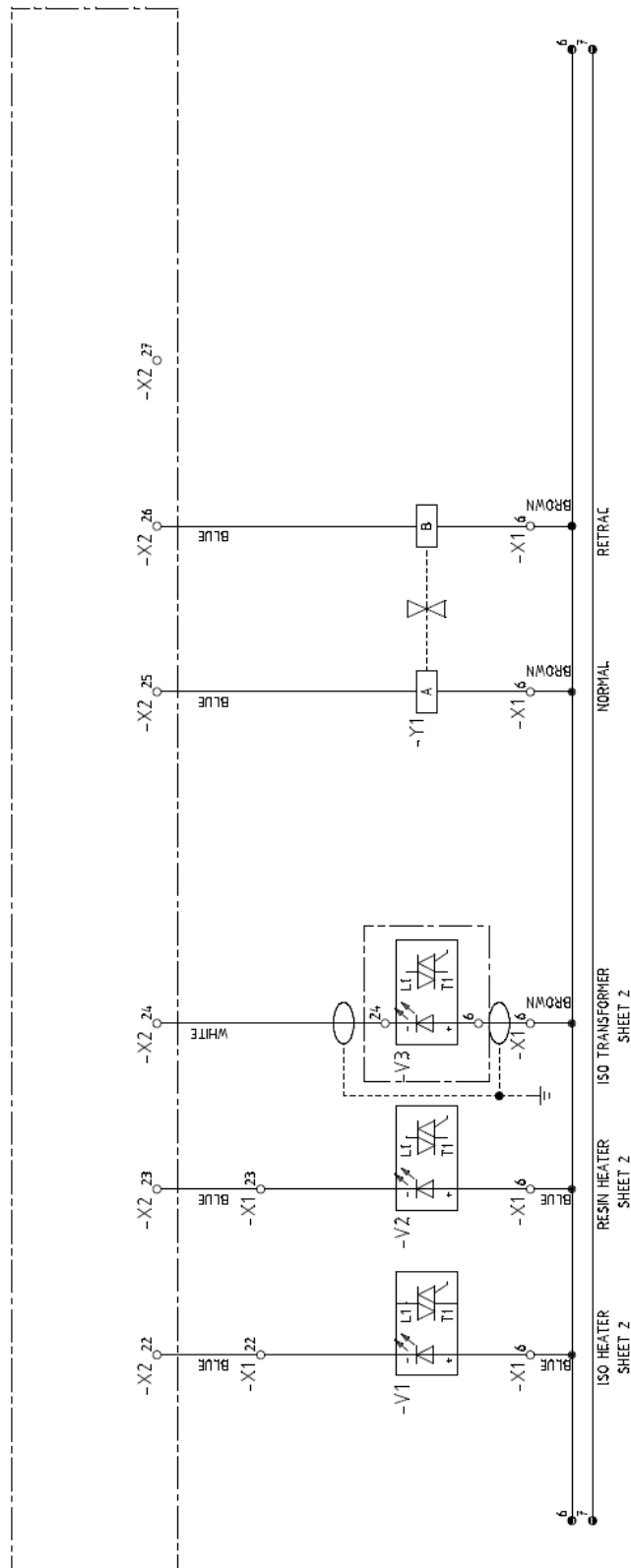

Figure 22. Electrical Schematic Diagram 3NPE~400V 50/60 Hz, Sheet 6 of 9

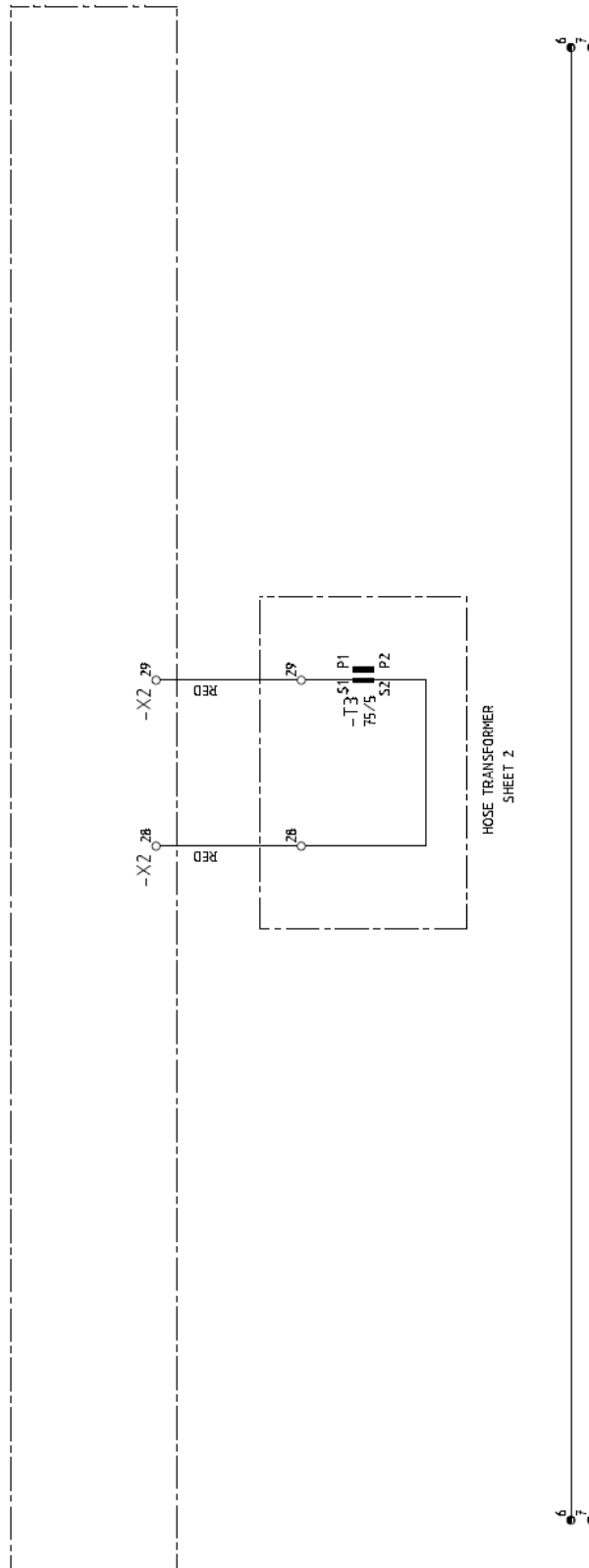

Figure 23. Electrical Schematic Diagram 3NPE~400V 50/60 Hz, Sheet 7 of 9

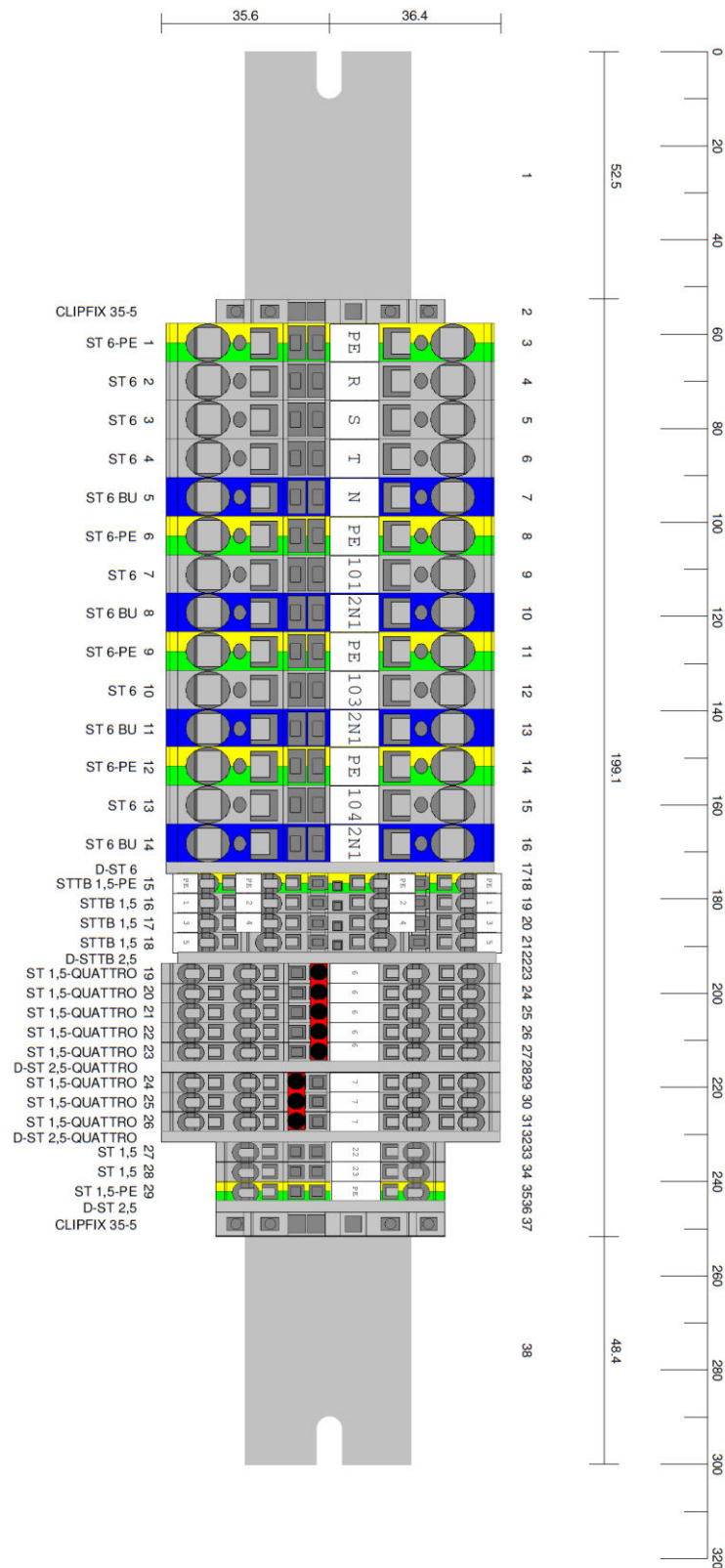

Figure 24. Electrical Distribution 3NPE~400V 50/60 Hz, Sheet 8 of 9

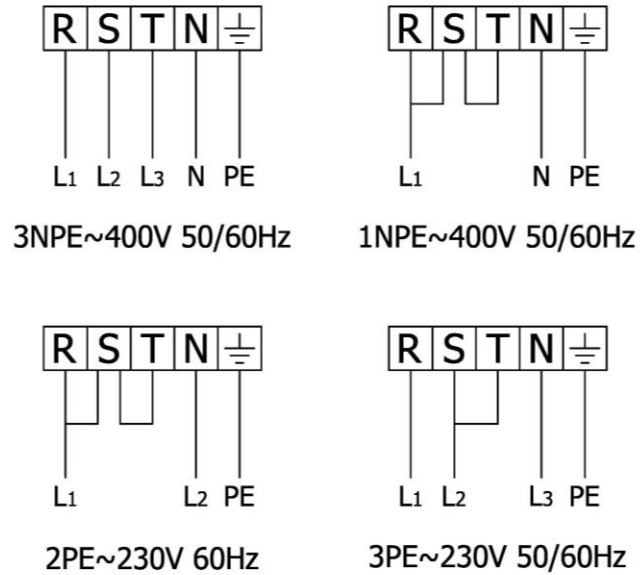

Figure 25. Electrical Connections 3NPE~400V 50/60 Hz, Sheet 9 of 9



Table 26. Electrical Schematic Diagram 3NPE~400V 50/60 Hz, Parts List

Ref.	Description	Part Number	Qty.
F10	Fusible Point	EL-00104-13	1
F10	Fuse	EL-00128-02	2
I1	Main Switch	EL-00107-18	1
I1	Auxiliar Switch	EL-00107-21	1
I1	Command Switch	EL-00107-19	1
T1	Transformer	EL-00127-01	1
D1	Differential Switch	EL-00108-00	1
F1	Circuit Breaker	EL-00109-00	1
F2	Circuit Breaker	EL-00115-01	1
F3	Circuit Breaker	EL-00115-01	1
F4	Circuit Breaker	EL-00112-00	1
T3	Intensity Transformer	EL-00127-03	1
V1	Static Relay	EL-00126-03	1
V2	Static Relay	EL-00126-03	1
V3	Triac	EL-00126-02	1
K1	Contactor	EL-00121-02	1
X1	Terminal Strip	EL-00105-00	1

PNEUMATIC SCHEMATIC DIAGRAM

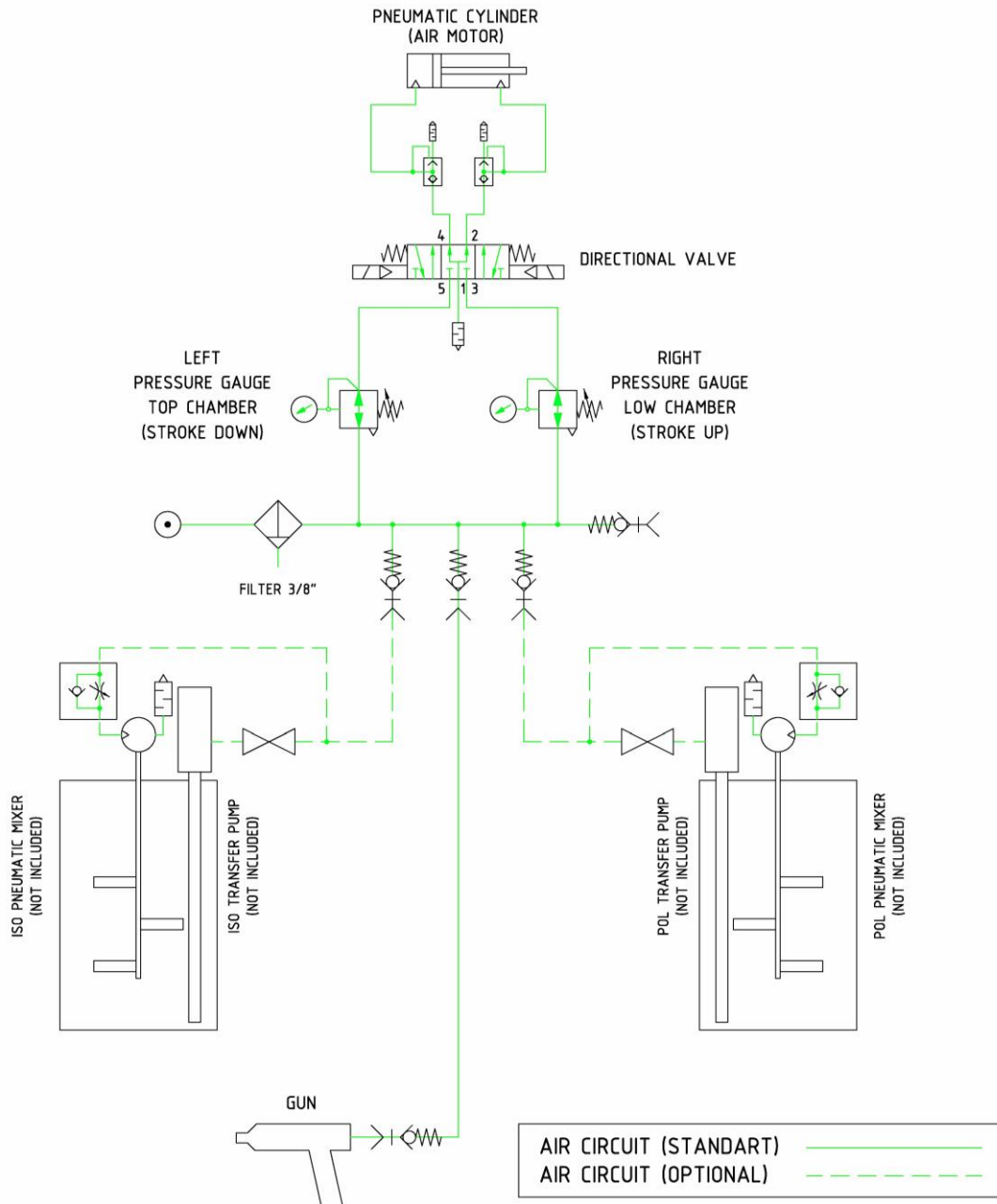

Figure 26. Pneumatic Schematic Diagram



FUNCTIONING SCHEMATIC DIAGRAM

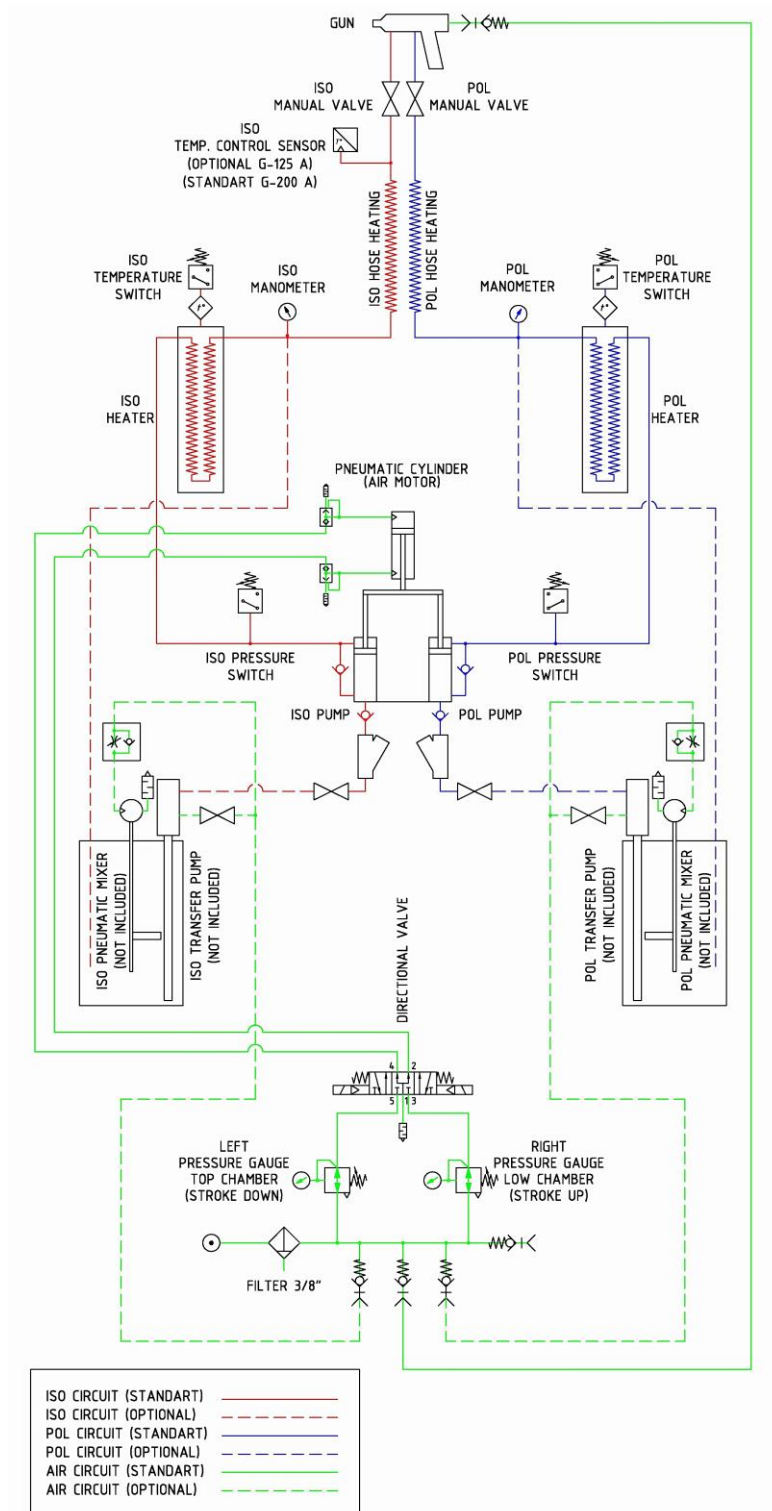

Figure 27. Functioning Schematic Diagram



CONTENT

Warranty	2
Safety and Handling	3
Proportioning Unit evolution G-125 A / G-200 A	4
Electrical Console evolution G-125 A Model	9
Electrical Console evolution G-200 A Model	11
Guide Wheels System	13
Connection Proportioning Pump	15
Proportioning Pump	18
Piston Rod Assembly	22
Air Control Assembly	26
Air Motor Assembly	29
“A” Primary Heater	31
“R” Primary Heater	34
Recirculation Kit P#: KT-00038	37
Recirculation Kit P#: KT-00038-01	38
Recirculation Kit P#: KT-00038-03	40
Electrical Schematic Diagram 3NPE~400V 50/60Hz	42
Pneumatic Schematic Diagram	52
Functioning Schematic Diagram	53
Content	54
List Of Illustrations	55
List Of Tables	56



LIST OF ILLUSTRATIONS

Figure 1. Proportioning Unit evolution G-125 A / G-200 A model _____	4
Figure 2. Generic Unions Detail, Proportioning Unit evolution G-125 A / G-200 A model _	5
Figure 3. Electrical Console evolution G-125 A Model _____	9
Figure 4. Electrical Console evolution G-200 A Model _____	11
Figure 5. Guide Wheel System, Exploded View. _____	13
Figure 6. Connection Proportioning Pump, Exploded View _____	15
Figure 7. Options of Assembly of the Pressure Switches _____	17
Figure 8. Product Pumps _____	18
Figure 9. Piston Rod Assembly, Exploded View _____	22
Figure 10. Air Control Assembly, Exploded View _____	26
Figura 11. Air Motor, Exploded view _____	29
Figure 12. "A" Primary Heater, Exploded View _____	31
Figure 13. "R" Primary Heater, Exploded View _____	34
Figure 14. Recirculation Kit P#: KT-00038, Exploded View _____	37
Figure 15. Recirculation Kit P#: KT-00038-01, Exploded View _____	38
Figure 16. Recirculation Kit P#: KT-00038-03, Exploded View _____	40
Figure 17. Electrical Schematic Diagram 3NPE~400V 50/60 Hz, Sheet 1 of 9 _____	42
Figure 18. Electrical Schematic Diagram 3NPE~400V 50/60 Hz, Sheet 2 of 9 _____	43
Figure 19. Electrical Schematic Diagram 3NPE~400V 50/60 Hz, Sheet 3 of 9 _____	44
Figure 20. Electrical Schematic Diagram 3NPE~400V 50/60 Hz, Sheet 4 of 9 _____	45
Figure 21. Electrical Schematic Diagram 3NPE~400V 50/60 Hz, Sheet 5 of 9 _____	46
Figure 22. Electrical Schematic Diagram 3NPE~400V 50/60 Hz, Sheet 6 of 9 _____	47
Figure 23. Electrical Schematic Diagram 3NPE~400V 50/60 Hz, Sheet 7 of 9 _____	48
Figure 24. Electrical Distribution 3NPE~400V 50/60 Hz, Sheet 8 of 9 _____	49
Figure 25. Electrical Connections 3NPE~400V 50/60 Hz, Sheet 9 of 9 _____	50
Figure 26. Pneumatic Schematic Diagram _____	52
Figure 27. Functioning Schematic Diagram _____	53



LIST OF TABLES

Table 1. Proportioning Unit evolution G-125 A / G-200 A model, Parts List	6
Table 2. R-Primary Heater Reference List	7
Table 3. A-Primary Heater Reference List	7
Table 4. Electrical Console Reference List	7
Table 5. Motor/Pump Assembly Reference List	8
Table 6. Electrical Console evolution G-125 A Model, Parts List	10
Table 7. Electrical Console evolution G-200 A Model, Parts List	12
Table 8. Guide Wheels System, Parts List	14
Table 9. Connection Proportioning Pump, Parts List	16
Table 10. Optional Assemblies of the Pressure Switch, Parts List	17
Table 11. Proportioning Pump, Parts List	19
Table 12. Proportioning Pump evolution G-125 A, Variant SIZE, Parts List	20
Table 13. Piston Rod Assembly, Parts List	23
Table 14. Piston Rod Size, Parts List	24
Table 15. Repair Seals Kit, Parts List	25
Table 16. Air Control Assembly, Parts List	27
Table 17. Pneumatic Tubes List, G-125/200 A Model	28
Table 18. Air Motor Assembly, Parts List	30
Table 19. A” Primary Heater, Parts List	32
Table 20. Parts List for each model of A-Heater	33
Table 21. “R” Primary Heater, Parts List	35
Table 22. Parts List for each model of R-Heater	36
Table 23. Recirculation Kit evolution, Parts List	37
Table 24. Recirculation Kit evolution, Parts List	39
Table 25. Recirculation Kit evolution, Parts List	41
Table 26. Electrical Schematic Diagram 3NPE~400V 50/60 Hz, Parts List	51