



# Parts Manual

## Spray Gun

### G-DI Series

Issue 4.2    29/09/25  
Ref. NR-00028-ENG



***Before starting or doing maintenance on the G-DI gun, carefully read all of the technical and safety documentation included in the Service Manual. Special attention should be paid to the information in order to know and understand the handling and conditions of use of the gun. This information is aimed at USER SAFETY and the PREVENTION OF PROBLEMS.***



## WARRANTY

HI-TECH SPRAY EQUIPMENT, S. A. (hereinafter "HI-TECH") grants this Limited Guarantee to the original buyer (hereinafter the "Client") for the unit and the original accessories given with the unit (hereinafter the "Product") against any fault in the design, materials or manufacture of the Product at the time of the first purchase by the user and for a duration of two (2) years thereafter, except in the case of hoses and TSU's, which will have a warranty period of one (1) year. Additionally, for any other product manufactured by external suppliers, the warranty period will be as specified by the manufacturer.

If during the guarantee period and under normal conditions of use, the Product should fail to work correctly due to defects of design, material or manufacture, the authorised distributor of the country where the HI-TECH Product or technical assistance service has been purchased shall repair or replace the Product in accordance with what is established in the following:

### CONDITIONS

- a) The validity of this guarantee will be subject to the presentation of the original invoice issued by the HI-TECH authorised distributor for the sale of the Product along with the Product handed over for repair or replacement, which must show the date of purchase and the serial number. HI-TECH reserves the right to refuse to give the guarantee service when the indicated data fail to appear on the invoice or have been modified after the purchase of the Product.
- b) The repaired or replaced Product will continue to maintain the original guarantee for the time remaining until the end of the guarantee or for three (3) months from the repair date, if the remaining period of the original guarantee were shorter.
- c) This guarantee will not be applied to the faults in the Product caused by its faulty installation, the natural wear and tear of the components, any use other than that considered normal for this Product or which should fail to strictly comply with the instructions of use provided by HI-TECH; due to accident, carelessness, adjustments, alterations or modifications of the Product not authorised by HI-TECH or due to the use of accessories, heating devices, pumping equipment and/or dispensers that have not been approved or manufactured by HI-TECH.
- d) The guarantee applicable to the components and accessories forming part of the Product and which have not been made by HI-TECH will be limited to the guarantee offered by the original manufacturer thereof.

**HI-TECH WILL NOT RECOGNISE ANY EXPRESS ORAL OR WRITTEN GUARANTEES OTHER THAN THIS PRINTED LIMITED GUARANTEE. ALL IMPLICIT GUARANTEES, INCLUDING, WITHOUT LIMIT, ADAPTATION FOR A SPECIFIC USE, ARE SUBJECT TO THE DURATION OF THIS WRITTEN GUARANTEE. HI-TECH DOES NOT ASSUME ANY KIND OF COMMITMENT OR RESPONSIBILITY FOR ALL POSSIBLE DAMAGE OR EXPENSE CAUSED BY FAULTS IN THE OUTPUT OF THE PRODUCT, ITS WORKING OR THE DISPENSING OF MATERIAL THROUGH THE PRODUCT, INCLUDING, WITHOUT LIMITATION, ALL EXPENSES CAUSED BY DAMAGE TO PEOPLE OR PROPERTY. EQUALLY, HI-TECH WILL IN NO CASE ACCEPT LIABILITY FOR THE LOSS OF SPECULATIVE PROFITS OR COMMERCIAL LOSSES. ALL REPAIRS OR REPLACEMENT OF FAULTY PRODUCTS WILL CONSTITUTE THE COMPREHENSIVE FULFILMENT OF HI-TECH'S OBLIGATIONS WITH RESPECT TO THE CLIENT. HI-TECH DOES NOT IN ANY WAY GUARANTEE THE SUITABILITY OR APTITUDE OF ITS PRODUCT FOR ANY PARTICULAR PURPOSE OR APPLICATION.**

All information provided on components which have not been manufactured by HI-TECH and which is based on reports received from the original manufacturer, though considered precise and reliable, is provided without any guarantee or responsibility of any explicit or implicit kind.

All concession, sale or financial leasing of the Product by HI-TECH in no case explicitly or implicitly constitutes any authorisation, acceptance or concession for the use of any rights or patents, nor does it encourage, nurture or back their infringement.

The restrictions on the guarantee suppose no limitation on the legal rights of the consumer established in applicable national legislation, nor do they affect any rights derived from the bargain and sale agreement between the consumer and supplier.

All information provided in this manual has been included in the confidence that it is true, although it does not constitute any responsibility or implicit or explicit guarantee. HI-TECH reserves the right at any time and without prior warning to make all improvements and modifications necessary to this manual, in order to rectify any possible typographical errors, increase the information contained or insert the changes caused to the characteristics and performance of the unit.



## SAFETY AND HANDLING

The equipment described in this manual has been designed and manufactured in compliance with the following European Directives, following as application guide the harmonized standards detailed and in conformity with the relevant UK Statutory Instruments (and their amendments):

**2006/42/EC Machinery Directive**

**2014/35/EU Low Voltage Directive**

**2014/30/EU EMC Directive**

**2011/65/EU RoHS Directive with amendment 2015/863**

**2012/19/EU Directive on waste electrical and electronic equipment**

Standards used:

EN ISO 12100:2010

EN 60204-1:2018

EN IEC 61000-6-4:2019

EN IEC 61000-6-2:2019

EN IEC 63000:2018

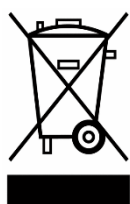

Electrical products cannot be thrown out with the rubbish. They must be taken to a dedicated collection point for an environmentally sound disposal in accordance with local regulations. You must contact your local collective or retailer for information about recycling. Before leaving WEEE at appropriate collection facilities, batteries must be removed and disposed of separately for proper recycling. The packaging materials are recyclable. Dispose of packaging materials in an environmentally sound manner and place them at the disposal of recycling sectors.

### TRANSPORT AND STORAGE

Proper precautions must be taken so that the equipment can withstand the effects of transport and storage temperatures between  $-25^{\circ}\text{C}$  and  $+55^{\circ}\text{C}$  or up to  $+70^{\circ}\text{C}$  for short periods that do not exceed 24 hours. Also, appropriate means to prevent damage from moisture, vibrations or shocks must be foreseen.



**BASIC CONFIGURATIONS**

BASIC CONFIGURATIONS					
Production	Pattern	Ref.	Composition		Qty.
LOW	"ROUND"	G-DI/RL	Base Gun	G-DI-00	1
			Module N° 1 + 3	GU-04021-035R	1
				GU-04021-045R	1
			PCD 05RS + 06RS	GU-04023-05RS GU-04023-06RS	1 1
			Valving Rood 0.98	GU-04006-00	1
			Rear Seal Retainer 0.98	GU-04019-01	1
	Rear Seal 0.98	GU-04020-01	1		
	"FLAT"	G-DI/FL	Base Gun	G-DI-00	
			Module N° 2 + 4	GU-04021-035F	1
				GU-04021-045F	1
			PCD 035FS + 028 FS	GU-04024-035FS GU-04024-028FS	1 1
			Valving Rood 0.98	GU-04006-00	1
Rear Seal Retainer 0.98			GU-04019-01	1	
Rear Seal 0.98	GU-04020-01	1			
HIGH	"ROUND"	G-DI/RH	Base Gun	G-DI-00	1
			Module N° 6 + 7 + 9 + 10	GU-04022-060R	1
				GU-04022-080R	1
				GU-04022-120R	1
				GU-04022-170R	1
			PCD 10RL + 14RL + 18RL + 23RL	GU-04023-10RL	1
				GU-04023-14RL	1
	GU-04023-18RL GU-04023-23RL	1 1			
	Valving Rood 1.25	GU-04007-00	1		
	Rear Seal Retainer 1.25	GU-04019-02	1		
	Rear Seal 1.25	GU-04020-02	1		
	"FLAT"	G-DI/FH	Base Gun	G-DI-00	1
			Module N° 5 + 8	GU-04022-045F	1
				GU-04022-080F	1
PCD 063FL + 084FL + 086FL + 117FL			GU-04024-063FL	1	
			GU-04024-084FL	1	
			GU-04024-086FL	1	
			GU-04024-117FL	1	
Valving Rood 1.25	GU-04007-00	1			
Rear Seal Retainer 1.25	GU-04019-02	1			
Rear Seal 1.25	GU-04020-02	1			



## SPECIFIC CONFIGURATIONS FOR EASY SPRAY-H

SPECIFIC CONFIGURATIONS FOR EASY SPRAY - H					
Output Q(l/min.)	Pattern	Ref.	Composition		Qty.
3,78	"FLAT"	<b>GDI-863</b>	Base Gun	G-DI-00	1
			Module N°8	GU-04022-080F	2
			PCD 063FL	GU-04024-063FL	2
			Valving Rood 1.25	GU-04007-00	1
			Rear Seal Retainer 1.25	GU-04019-02	1
			Rear Seal 1.25	GU-04020-02	1
3,60	"ROUND"	<b>GDI-614</b>	Base Gun	G-DI-00	1
			Module N°6	GU-04022-060R	2
			PCD 014RL	GU-04023-014RL	2
			Valving Rood 1.25	GU-04007-00	1
			Rear Seal Retainer 1.25	GU-04019-02	1
			Rear Seal 1.25	GU-04020-02	1
1,15	"FLAT"	<b>GDI-428</b>	Base Gun	G-DI-00	1
			Module N°4	GU-04021-045F	2
			PCD 028FS	GU-04024-028FS	2
			Valving Rood 0.98	GU-04006-00	1
			Rear Seal Retainer 0.98	GU-04019-01	1
			Rear Seal 0.98	GU-04020-01	1

**Output Q(l/min) @ 140 bar**

**Note: Outputs are approximated, values can change depending on the densities and temperatures of the chemicals.**

**GRIP AND AIR CYLINDER ASSEMBLY**

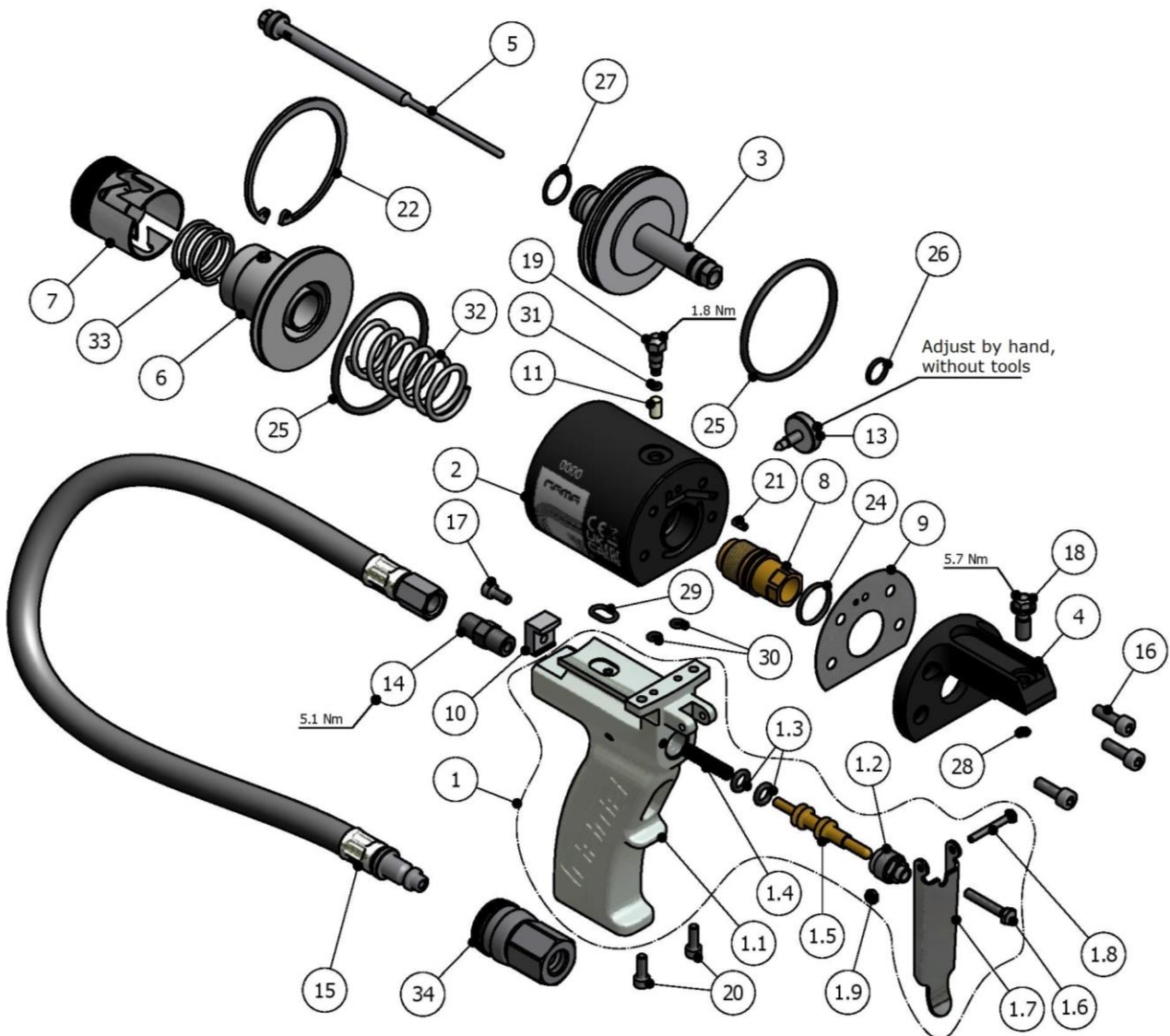

**Figure 1. Grip and Air Cylinder Assembly, G-DI Gun**



**Table 1. Grip and Air Cylinder Parts List,  
G-DI Gun**

Pos.	Description	Reference	Qty.
1	Sleeve with Trigger Unit	GU-04001-02	1
1.1	Machined Sleeve with Caps (*)	GU-04048-01	1
1.1A	Machined and Anodized Sleeve without Caps (°)	GU-04048-00	1
1.1B	Caps (°)	TN-00251	6
1.2	Trigger Valve Nut (*)	GU-02131	1
1.3	O-ring (*)	OR-00079	2
1.4	Trigger spring (*)	SP-00022	1
1.5	Trigger shaft (*)	GU-02130	1
1.6	Trigger Stop Bolt (*)	TN-00235	1
1.7	Trigger (*)	GU-02132	1
1.8	Trigger Screw (*)	TN-00459	1
1.9	Retention Nut (*)	TN-00460	1
2	Mechanical Gun Standard Sleeve	GU-04002	1
3	Plunger Unit	GU-04008-00	1
4	Mix Block Support	GU-04016	1
5	Valving Rod 098 Size	GU-04006-00	1
	Valving Rod 125 Size	GU-04007-00	1
6	Cylinder block unit	GU-04003-04	1
7	Blocking device	GU-04003-02	1
8	Valving Rod Guide	GU-04009	1
9	Paper Seal	GU-04013	1
10	Sleeve Staple	GU-02021	1
11	Friction Bushing	GU-04012	1
12			
13	Air Regulator	GU-04015	1
14	Hex. Nipple	RA-00112	1
15	Hose Air Supply	MA-00027	1
16	Allen Bolt	TN-00016	4
17	Allen Bolt	TN-00002	1
18	Mix Block Bolt	GU-04037	1
19	Bushing Pressure Bolt	GU-04011	1



Pos.	Description	Reference	Qty.
20	Allen Bolt	TN-00049	2
21	Pin	TN-00224	1
22	Retention Ring	TN-00223	1
24	O-ring	OR-00070	1
25	O-ring	OR-00072	2
26	O-ring	OR-00003	1
27	O-ring	OR-00025	1
28	O-ring	OR-00147	1
29	O-ring	OR-00015	1
30	O-ring	OR-00001	2
31	O-ring	OR-00047	1
32	Plunger Spring	SP-00015A	1
33	Blocking Spring	SP-00007	1
34	Quick Connect Air Supply	RA-00109	1

**N.B.:**

**(\*) Parts included in POS.1**

**(°) Parts included in POS. 1.1**



## HEAD ASSEMBLY

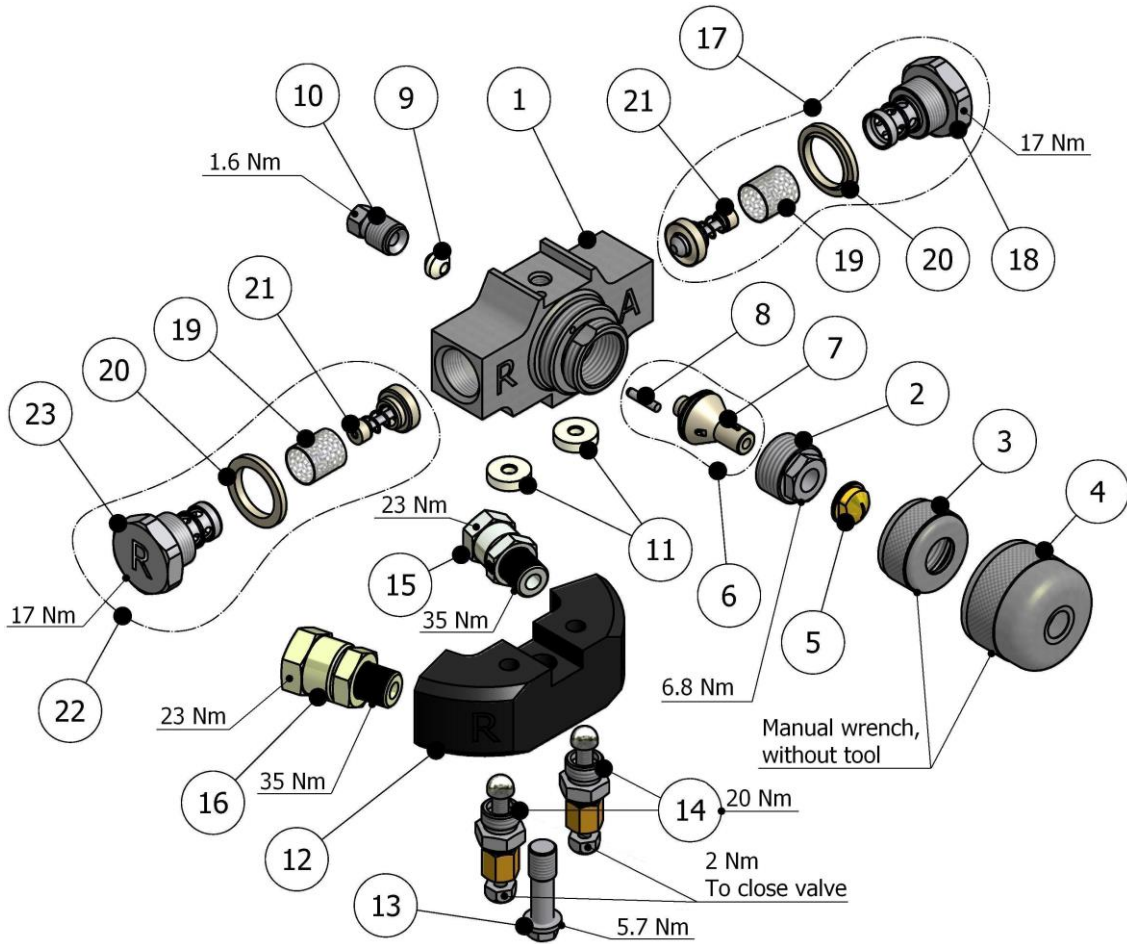

Figure 2. Head Assembly, G-DI Gun



**Table 2. Head Assembly Parts List,  
G-DI Gun**

Pos.	Description	Reference	Qty.
1	Mixhead	GU-04017	1
2	Valving Rod Seal Nut	GU-04018	1
3	TIP Nut	GU-04025	1
4	Diffuser	GU-04026	1
5	PCD	See Table 6, Table 7, Table 8 & Table 10	-
6	Module with Pin	See Table 6, Table 7, Table 8 & Table 9	-
7	Module (Included in Pos. 6)		-
8	Pin (Included in Pos. 6)	TN-00227	-
9	Rear Seal 098 Size	GU-04020-01	1
	Rear Seal 125 Size	GU-04020-02	1
10	Rear Seal Retainer 098	GU-04019-01	1
	Rear Seal Retainer 125	GU-04019-02	1
11	Input Block Seal	GU-03012	2
12	Input Block Unit	GU-02115-00	1
13	Input Block Screw	GU-04036	1
14	Manual Valve Unit	GU-02020-00G	2
15	Connection Male – Free Nut (ISO)	RA-00005	1
16	Connection Male – Free Nut (POL)	RA-00006	1
17	Filter and Non-Return Cartridge Unit (ISO)	GU-04030-01	1
18	Side Filter Cartridge Housing (ISO) (*)	GU-04028-01	1
19	Filter 40 Mesh (*),(#) <b>(standard)</b>	GU-02063-40	2
	Filter 60 Mesh <b>(Optional)</b>	GU-02063-60	2
	Filter 80 Mesh <b>(Optional)</b>	GU-02063-80	2
20	Side Filter Cartridge Seal (*),(#)	GU-04030	2
21	Non-Return Valve Unit (*),(#)	GU-03010-00	2
22	Filter and Non-Return Cartridge Unit (POL)	GU-04030-02	1
23	Side Filter Cartridge Housing (POL) (#)	GU-04028-02	1

**N.B.:** (\*) Parts included in POS.17 (#) Parts included in POS.22



### MAGNETIC PLUNGER ASSEMBLY (OPTIONAL)

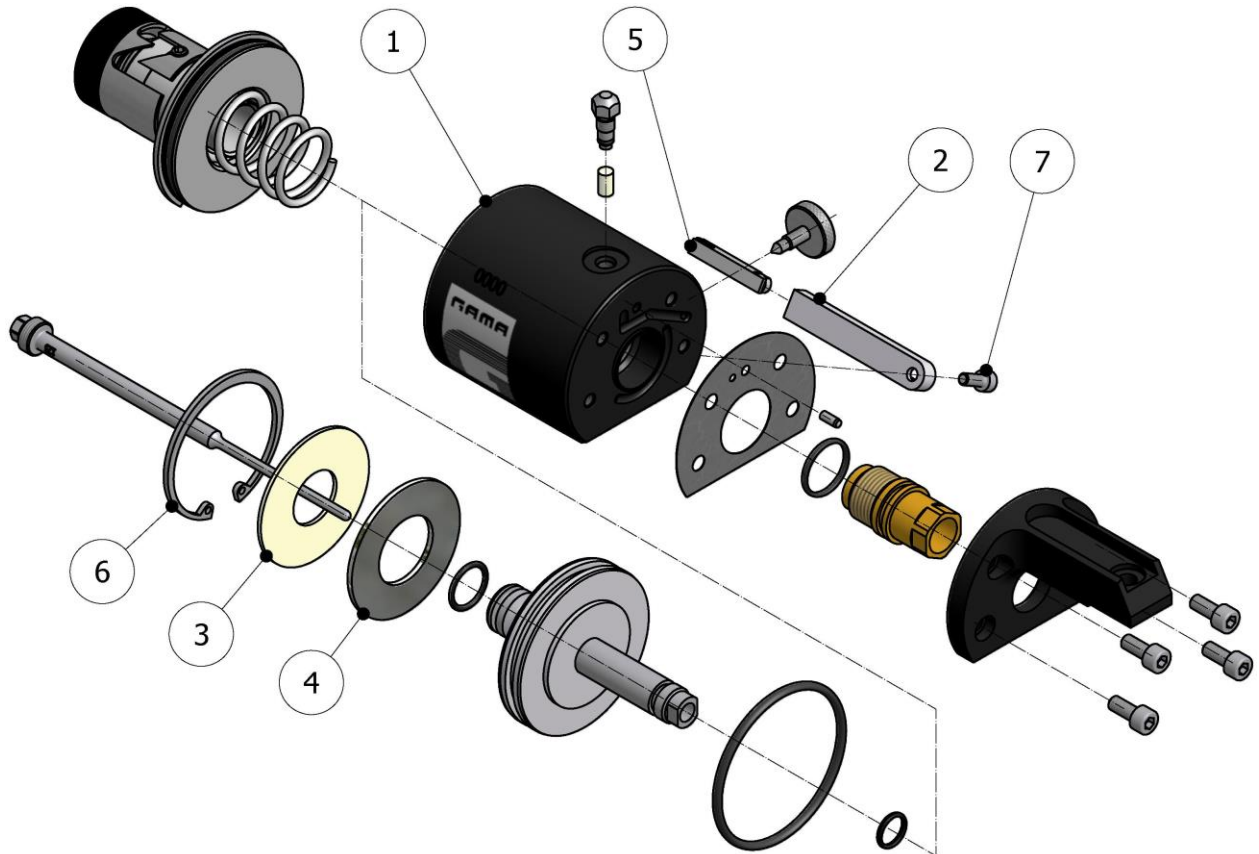

**Figure 3. Magnetic Plunger Assembly (Optional)**  
**G-DI Gun**



**Table 3. Magnetic Plunger Assembly Parts List (Optional),  
G-DI Gun**

Pos.	Description	Reference	Qty.
1	Sleeve for Standard Magnetic Micro	GU-04002-M	1
	Sleeve for Auto Version Magnetic Micro	GU-04002-A-MIC	1
	Sleeve for Timer Version Magnetic Micro	GU-04002-T-MIC	1
2	Detector Support	GU-02051	1
3	Plunger Magnet Cap	GU-04033	1
4	Plunger Magnet	GU-04040	1
5	Magnetic Detector	EL-00136-04 (*)	1
6	Retention Ring	TN-00222	1
7	Allen Bolt	TN-00002	1

**N.B.:**

***Fit the right sleeve for the version of the gun; Standard, Automatic or with Timer.***

**(\*) This Part includes:**

- ***1 Magnetic Switch with cable 2 m.***
- ***1 Square male connector of 3 poles.***



### TIMER ASSEMBLY (OPTIONAL)

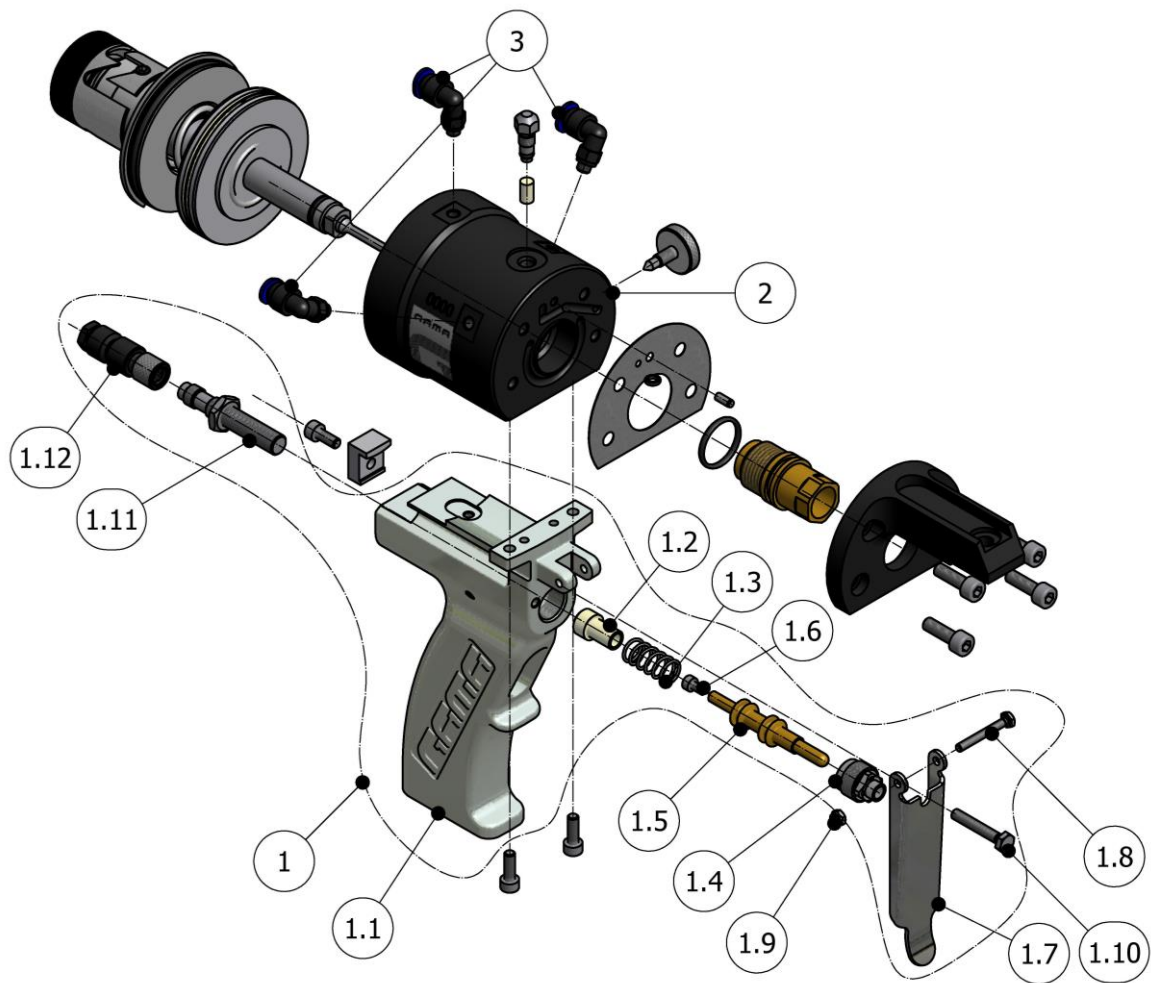

Figure 4. Timer Assembly (Optional), G-DI Gun



**Table 4. Timer Assembly Parts List (Optional),  
G-DI Gun**

Pos.	Description	Reference	Qty.
1	Sleeve Unit for Timer	GU-04001-02A	1
1.1	Machined and Anodized Sleeve for Timer (*)	GU-04048-A0	1
1.2	Spring Seat for Timer (*)	GU-02135	1
1.3	Trigger Spring for Timer (*)	SP-00023	1
1.4	Trigger Valve Nut (*)	GU-02131	1
1.5	Trigger Shaft for Timer (*)	GU-02130-A	1
1.6	Allen bolt (*)	TN-00020	1
1.7	Trigger (*)	GU-02132	1
1.8	Trigger Screw (*)	TN-00459	1
1.9	Retention Nut (*)	TN-00460	1
1.10	Trigger Stop Bolt (*)	TN-00235	1
1.11	Inductive Detector (*)	EL-00136-02	1
1.12	Cable Switch with Connectors (*)	EL-00136-07	1
2 (#)	Sleeve for Standard Timer	GU-04002-T	1
	Sleeve for Timer with Magnetic Micro	GU-04002-T-MIC	1
3	Kneed Pneumatic connector	RA-00088	3

**N.B.:**

**(\*) Parts included in POS.1**

**(#) Fit the right sleeve for the version of the gun; Standard, or with Magnetic Micro.**

## AUTO ASSEMBLY (OPTIONAL)

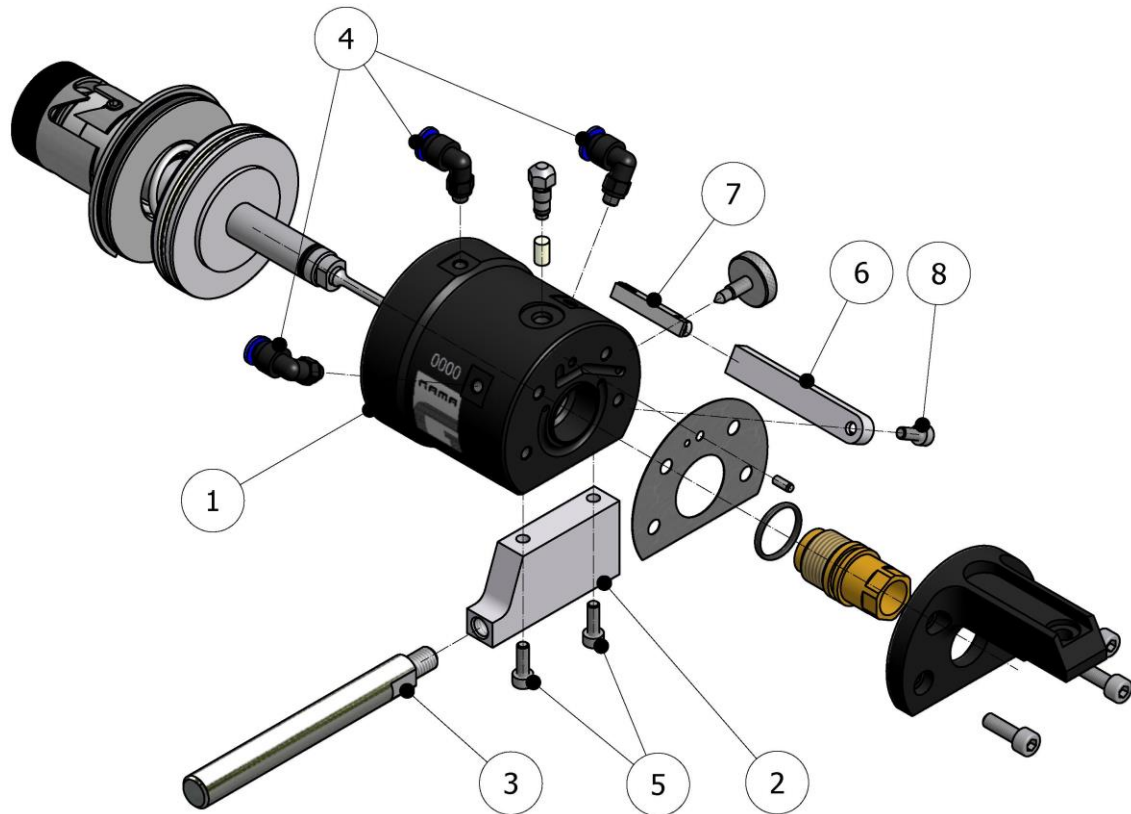

Figure 5. Auto Assembly (Optional), G-DI Gun

Table 5. Auto Assembly Parts List (Optional),  
G-DI Gun

Pos.	Description	Reference	Qty.
1	Auto Sleeve with Magnetic Switch	GU-04002-A-MIC	1
2	Auto Gun Support	GU-02136	1
3	Connection Rod	GU-02056	1
4	Knead Pneumatic connector	RA-00088	3
5	Allen Bolt	TN-00001	2
6	Detector Support	GU-02051	1
7	Magnetic Switch with cable 2m+Square connect.3 poles	EL-00136-04	1
8	Allen Bolt	TN-00002	1





**Table 7. "Flat" Projection Size Parts List,  
G-DI Gun**

Valving Rod Pos. 1	Rear Seal Retainer Pos. 2	Rear Seal Pos. 3	Module (Nº) Pos. 4	PCD Pos. 5	Size
GU-04006-00	GU-04019-01	GU-04020-01	GU-04021-035F (2) GU-04021-045F (4)	GU-04024-028FS GU-04024-035FS	098
GU-04007-00	GU-04019-02	GU-04020-02	GU-04022-080F (8) GU-04022-045F (5)	GU-04024-063FL GU-04024-084FL GU-04024-086FL GU-04024-117FL	125

**N.B.:** The Modules and PCD may be combined provided they are from the same Size family (see combinations in Table 8).

**Table 8. Configurations According to Application**

"ROUND SPRAY PATTERN" (# 098 SIZE))						
Production (Lts/min.)	Pressure (Kgf/cm <sup>2</sup> )	Module (Nº)	ISO Port/ POL Port (mm)	PCD	Fan Pattern (cm)	Dimens. Window (mm)
0,6 – 1,1	100-225	GU-04021-035R (1)	1x-0,35 ISO 1x-0,35 POL	GU-04023-05RS	10-15	0,5
1,1 – 1,6	100-225	GU-04021-045R (3)	1x-0,45 ISO 1x-0,45 POL	GU-04023-06RS	15-18	0,6
"FLAT SPRAY PATTERN" (# 098 SIZE)						
Production (Lts/min.)	Pressure (Kgf/cm <sup>2</sup> )	Module (Nº)	ISO Port/ POL Port (mm)	PCD	Fan Pattern (cm)	Dimens. Window (mm)
0,6 – 1,1	100-225	GU-04021-035F (2)	1x-0,35 ISO 1x-0,35 POL	GU-04024-035FS	10-15	1,26x0,28
1,5 – 2,2	100-225	GU-04021-045F (4)	1x-0,55 ISO 1x-0,55 POL			
0,5 – 1	100-225	GU-04021-035F (2)	1x-0,35 ISO 1x-0,35 POL	GU-04024-028FS	10-15	1,16x0,25
1 – 1,8	100-225	GU-04021-045F (4)	1x-0,55 ISO 1x-0,55 POL			



"ROUND SPRAY PATTERN" (# 125 SIZE)						
Production (Lts/min.)	Pressure (Kgf/cm <sup>2</sup> )	Module (N°)	ISO Port/ POL Port (mm)	PCD	Fan Pattern (cm)	Diam. Window (mm)
1,8 – 3,6	90-230	GU-04022-060R (6)	1x-0,70 ISO	GU-04023-10RL	15-25	1,0
1,8 – 3,9	70-250		1x-0,70 POL	GU-04023-14RL	15-40	1,4
3,0 – 4,8	110-240	GU-04022-080R (7)	1x-0,80 ISO 1x-0,80 POL	GU-04023-10RL	10-20	1,0
4,2 – 6,6	110-240			GU-04023-14RL	10-25	1,4
4,2 – 7,2	70-250			GU-04023-18RL	50-60	1,8
8 – 9	150			GU-04023-23RL	70-80	2,3
6	100	GU-04022-120R (9)	1x-1,20 ISO 1x-1,20 POL	GU-04023-10RL	10	1,0
7	120			GU-04023-14RL	25	1,4
7 – 9	70-90			GU-04023-18RL	50	1,8
12	150			GU-04023-23RL	70	2,3
7,5	70	GU-04022-170R (10)	1x-1,70 ISO 1x-1,70 POL	GU-04023-10RL	15	1
9	130			GU-04023-14RL	50	1,4
14	150			GU-04023-18RL	60	1,8
18	150			GU-04023-23RL	80	2,3
"FLAT SPRAY PATTERN" (# 125 SIZE)						
Production (Lts/min)	Pressure (Kgf/cm <sup>2</sup> )	Module (N°)	ISO Port/ POL Port (mm)	PCD	Fan Pattern (cm)	Dimens. Window (mm)
1 – 2,7	110-250	GU-04022-045F (5)	1x-0,45 ISO	GU-04024-063FL	30-50	1,63x0,39
1 – 3,5	110-230		1x-0,45 POL	GU-04024-084FL	30-50	1,63x0,52
1,8 – 3	110-230	GU-04022-080F (8)	1x-0,80 ISO 1x-0,80 POL	GU-04024-063FL	40-60	1,63x0,39
3 – 5,5	90-230			GU-04024-084FL	40-60	1,63x0,52
				GU-04024-086FL	40-60	2,02x0,45
4 – 7	110-240			GU-04024-117FL	40-60	1,93x0,61

**NB: Outputs are approximated, values can change depending on the densities and temperatures of the chemicals.**

**Test fluid: Mesamoll.**

**Dynamic stickiness: 100-130 mPa.s**

**Thickness: from 1,04 to 1,07 Kg/L**



**Table 9. List of Cleaning Drills for Modules**

Module Nº.	Module ref.	Diam. Central Drill	Diam. Drill and Ref.	Diam. Side Drills	Diam. Drill and Ref.
1	GU-04021-035R	2.376 mm	2,35 mm HT-00070	2x 0.35 mm	0.3 mm HT-00020
2	GU-04021-035F				0,4 mm HT-00021
3	GU-04021-045R			2x 0.45 mm	0,5 mm HT-00015
4	GU-04021-045F			2x 0.55 mm	
5	GU-04022-045F	3.175 mm	3.2 mm HT-00071	2x 0.45 mm	0,4 mm HT-00021
6	GU-04022-060R			2x 0.70 mm	0.65 mm HT-00079
7	GU-04022-080R			2x 0.80 mm	0.75 mm HT-00023
8	GU-04022-080F				
9	GU-04022-120R			2x 1.20 mm	1.15 mm HT-00024
10	GU-04022-170R			2x 1.70 mm	1.65 mm HT-00025

**N.B.:** Each Module is supplied with the corresponding cleaning drills.

**Table 10. List of Cleaning Drills for PCD "ROUND"**

Ref. PCD	Diam. Window	Diam. Drill	Drill Ref.
GU-04023-05RS	0.5 mm	0.45 mm	HT-00021
GU-04023-06RS	0.6 mm	0.55 mm	HT-00022
GU-04023-10RL	1 mm	0.95 mm	HT-00027
GU-04023-14RL	1.4 mm	1.35 mm	HT-00028
GU-04023-18RL	1.8 mm	1.75 mm	HT-00023
GU-04023-23RL	2.3 mm	2.25 mm	HT-00030

**N.B.:** Each PCD is supplied with the corresponding cleaning drill.

## PRODUCT INLET ASSEMBLY (OPTIONAL)

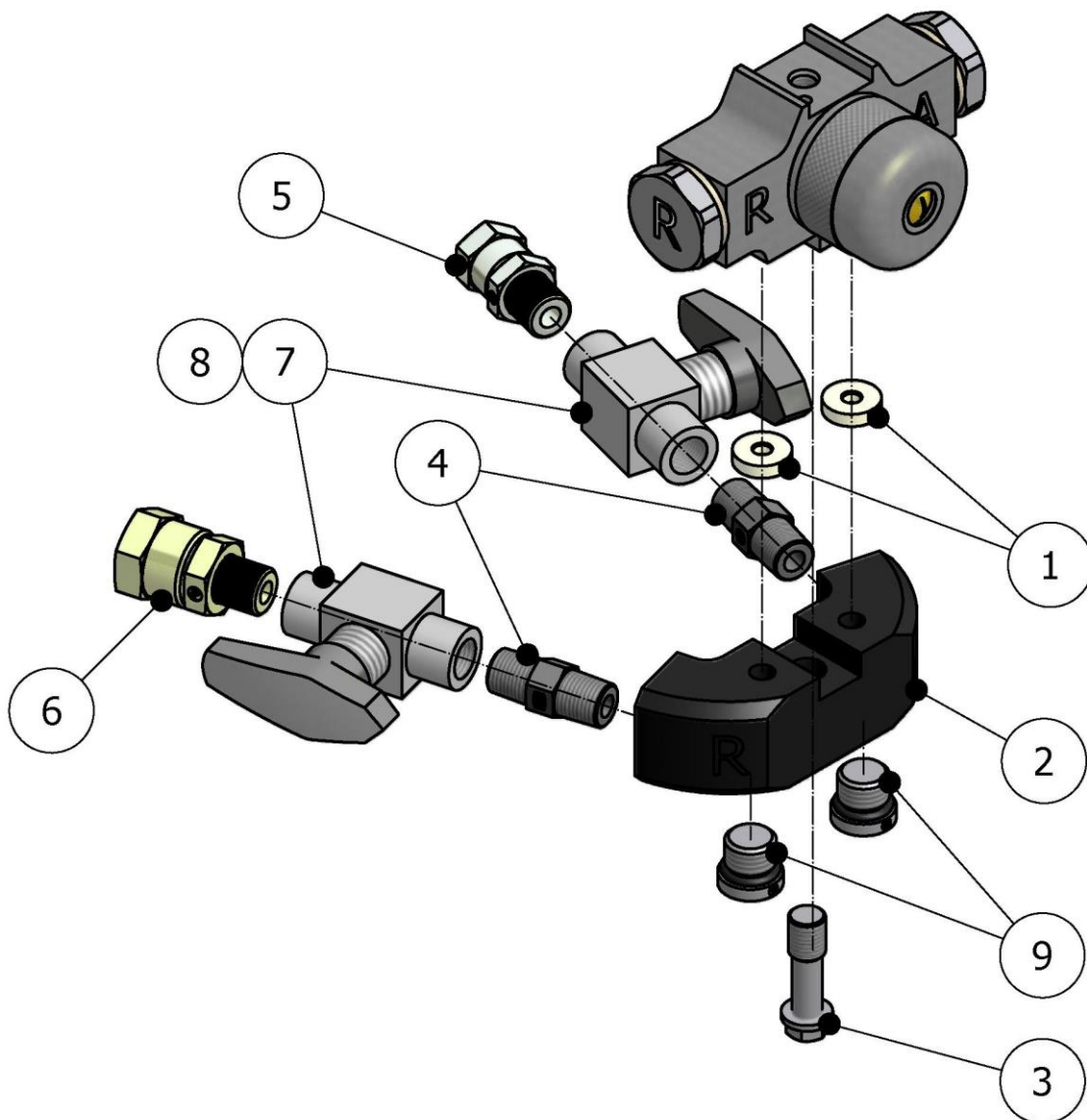

Figure 7. Product Inlet Assembly (Optional)



**Table 11. Product Inlet Assembly Parts List (Optional),  
G-DI Gun**

Pos.	Description	Reference	Qty.
1	Input Block Seal (*)	GU-03012	2
2	Input Block Unit (*)	GU-02115-00	1
3	Input Block Screw (*)	GU-04036	1
4	Hex. Nipple	RA-00112	2
5	Connection Male – Free Nut (ISO) (*)	RA-00005	1
6	Connection Male – Free Nut (POL) (*)	RA-00006	1
7	Standard Ball Valve	RA-00070	2
8	High Pressure Ball Valve (#)	RA-00070H	2
9	Stopper	RA-00242	2

**(\*) Parts included in the standard gun.**

**(#) Express supply to order. Consult delivery time with the Marketing department.**

### SPECIAL PROJECTION ASSEMBLIES (OPTIONAL)

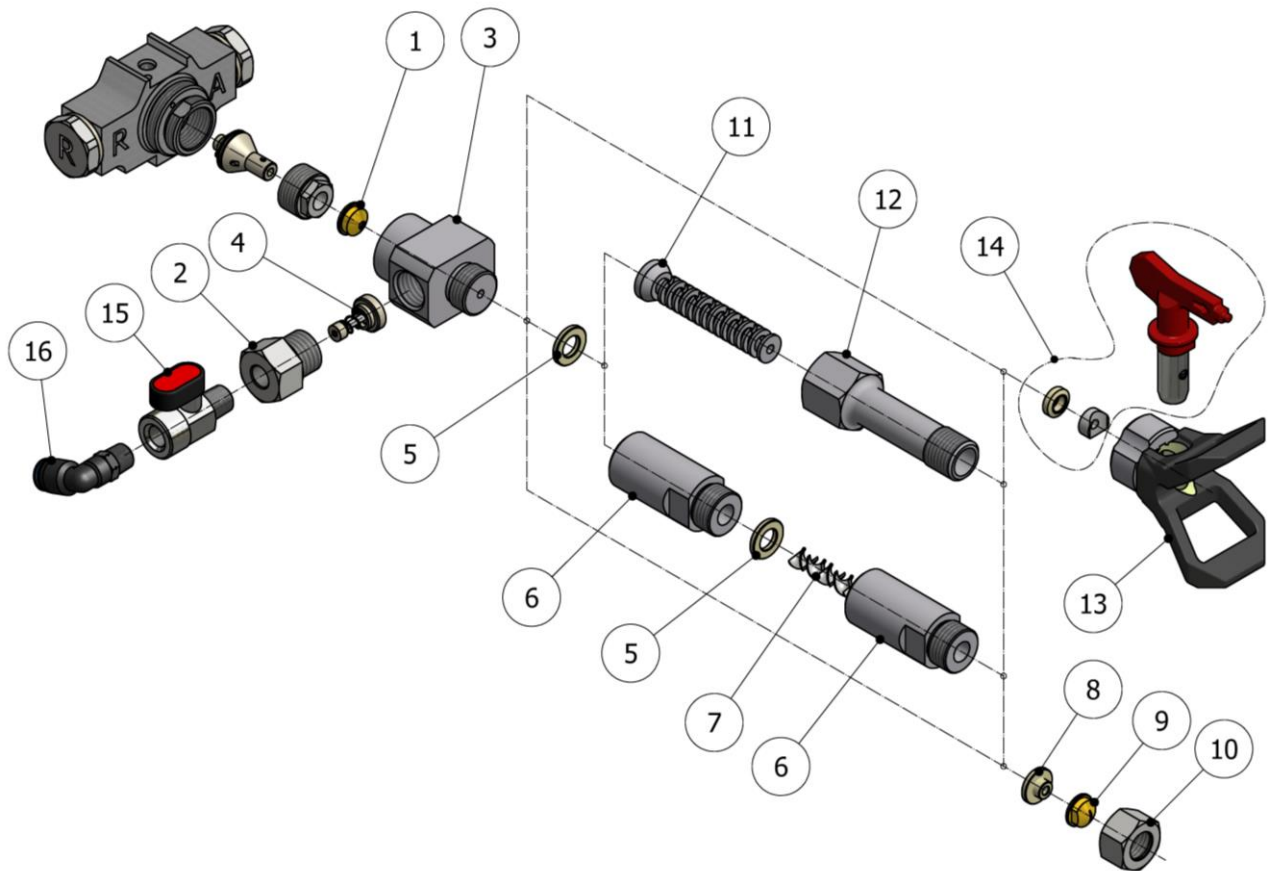

Figure 8. Special Projection Assemblies (Optional)



**Table 12. Special Projections Parts List (Optional)**

Pos.	Description	Reference	Qty.
1	PCD for Valving Rod 125 "Round"	GU-04023-23RL	1
2	Clean Inlet Port	GU-04055B	1
3	Cleaning Body	GU-04044A	1
4	Non-Return Unit	GU-03010-00	1
5	Seal	GU-05019	(*) (#)
6	Modular Mixer Sleeve	GU-05018-50	(*)
7	Mixer Drill	See Table 13	(*)
8	PCD Base Seal	GU-04039	1
9	PCD "Flat"	See Table 14	1
10	PCD Nut	GU-04047	1
11	Labyrinth Type Mixer	GU-04046	(#)
12	Labyrinth Mixer Sleeve	GU-04045	(#)
13	Nozzle Guard	GU-05017	1
14	Reversible TIP Unit (includes seal and seat)	See Table 16	1
15	Ball Valve	RA-00240	1
16	Elbow 90°	RA-00093	1

(\*) See Table 13

(#) See Table 15

**N.B.:** To order any part of these assemblies, consult the delivery time with the Marketing department.



**Table 13. Modular Static Mixer Parts List.**

Long. Mixer	Pos. 5 GU-05019	Pos. 6 GU-05018-50	Pos 7
50 mm	1x	1x	1x GU-02047-050
100 mm	2x	2x	1x GU-02047-100
150 mm	3x	3x	1x GU-02047-150
200 mm	4x	4x	1x GU-02047-200
300 mm	6x	6x	1x GU-02047-300

**Table 14. Standard PCD Size List.**

Standard PCD	Hole Size mm	Fan Width cm (*)
GU-04024-028FS	0,25x1,16	---
GU-04024-035FS	0.28x1.26	---
GU-04024-063FL	0.39x1.63	---
GU-04024-084FL	0.52x1.63	---
GU-04024-086FL	0.45x2.08	---
GU-04024-117FL	0.61x1.93	---

*(\*) Values obtained with water at 130 bar and 30 cm from the surface to be projected.*

*Delivery times for these elements, consult the Marketing department.*

**Table 15. Labyrinth Static Mixer Component List.**

Long. Mixer	Pos. 5 GU-05019	Pos. 11 GU-04046	Pos 12 GU-04045
50 mm	1x	1x	1x
100 mm	2x	2x	2x
150 mm	3x	3x	3x
200 mm	4x	4x	4x
250 mm	5x	5x	5x



**Table 16. List of Reversible TIP Sizes.**

TIP	Hole Size mm	Fan Width cm (*)
GU-05016-2310	0. 58	10
GU-05016-2320	0. 58	20
GU-05016-2340	0. 58	40
GU-05016-2720	0. 69	20
GU-05016-2730	0. 69	30
GU-05016-3520	0. 90	20
GU-05016-3530	0. 90	30
GU-05016-3540	0. 90	40

*(\*) Values obtained with water at 130 bar and 30 cm from the surface to be projected.*

*Delivery times for these elements, consult the Marketing department.*

## ASSEMBLY POUR ADAPTER (OPTIONAL)

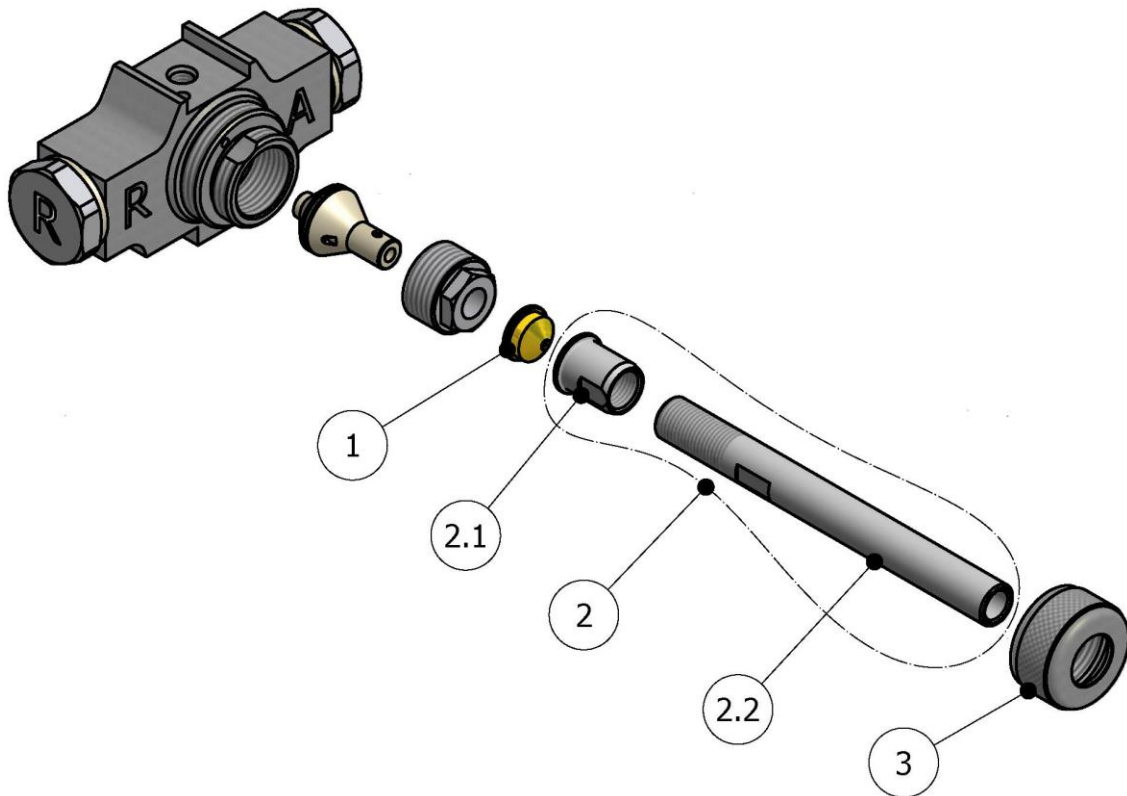

Figure 9. Assembly Pour Adapter (Optional)

Table 17. Assembly Pour Adapter, Parts List (OPTIONAL)

Pos.	Description	Reference	Qty.
1	PCD for rod 125 "Round"	GU-04023-23RL	1
2	Pour Nozzle	GU-04052	1
2.1	Nozzle Head	GU-04050	1
2.2	Nozzle Pipe	GU-04051	1
3	Nozzle Nut	GU-04053	1

**N. B.:**

(\*) Parts included in Pos.2

Delivery times for these elements, consult the Marketing department.

## RECIRCULATION KIT (OPTIONAL)

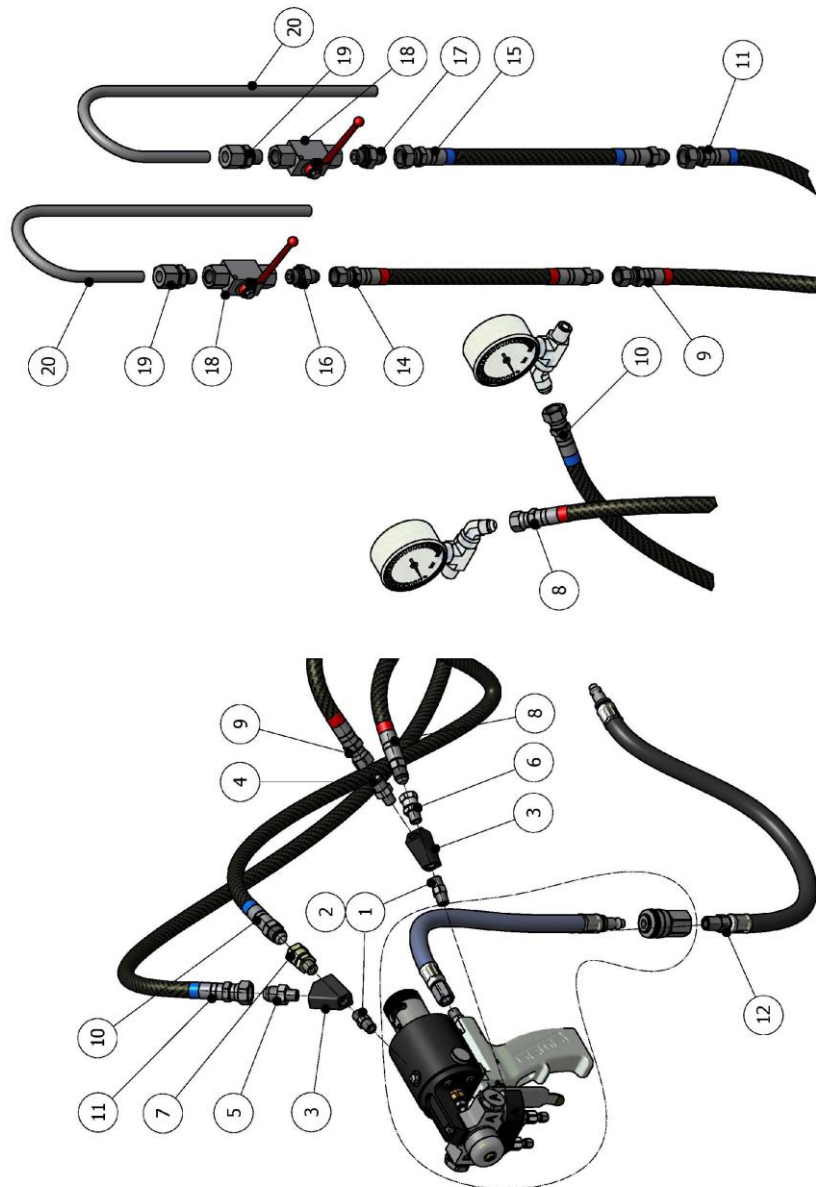

Figure 10. Recirculation Kit (Optional)  
KT-00059-9

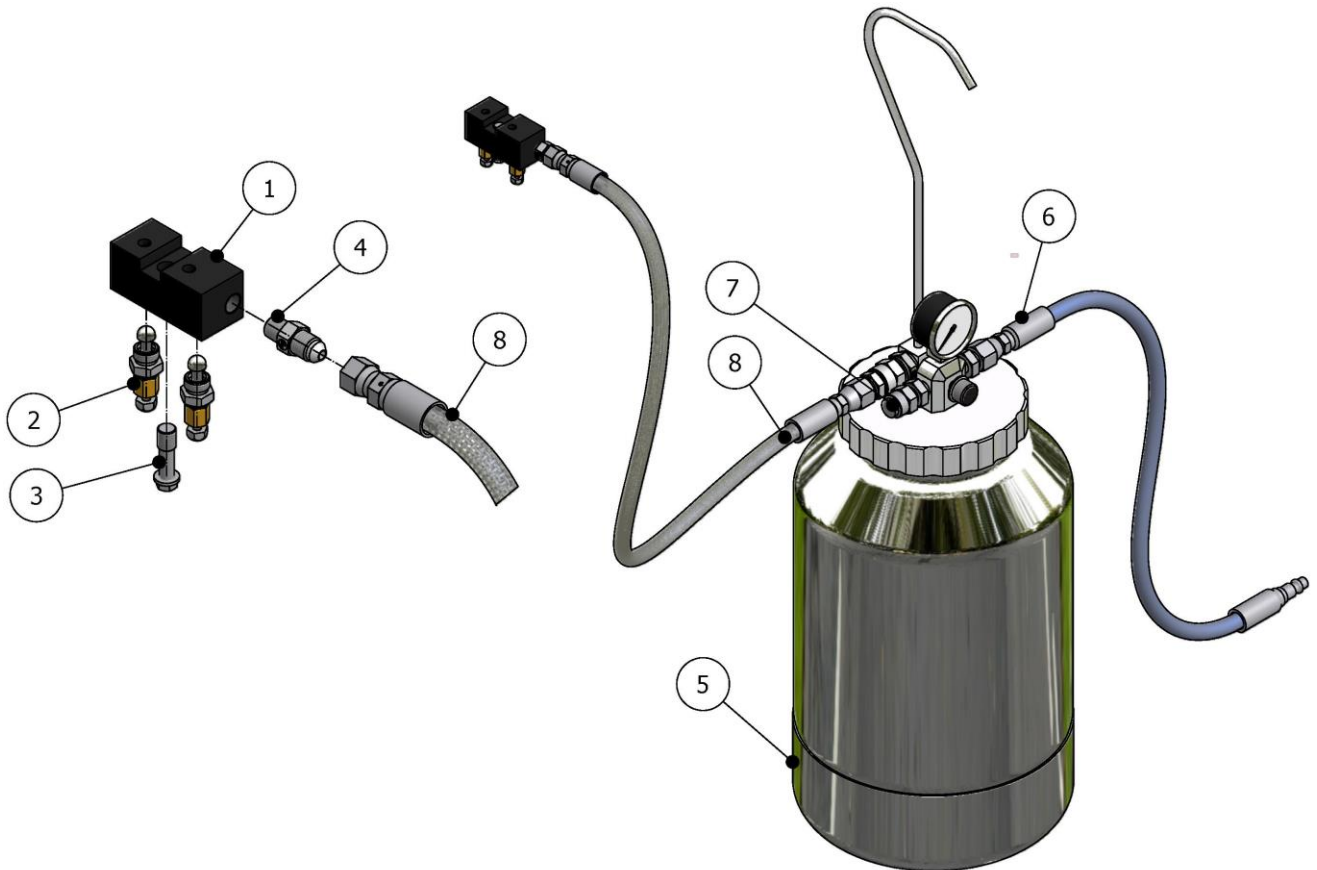

**Table 18. Recirculation Kit Parts List (OPTIONAL)**  
**KT-00059-9**

Item.	Description	Part Number	Qty.
1	Nipple	RA-00112	2
2	Elbow	RA-00205	2
3	Manifold	RA-00464	2
4	Nipple	RA-00238	1
5	Nipple	RA-00237	1
6	Swivel (*)	RA-00005	1
7	Swivel (*)	RA-00006	1
8	Flex 10000 mm Supply ISO	MA-00060-3	1
9	Flex 10000 mm Recirculation ISO	MA-00060-2	1
10	Flex 10000 mm Supply POL	MA-00059-3	1
11	Flex 10000 mm Recirculation POL	MA-00059-2	1
12	Air Hose	MA-00194	1
13			
14	Flex 1000 mm Recirculation Extended ISO	MA-00177	1
15	Flex 1000 mm Recirculation Extended POL	MA-00178	1
16	Nipple	RA-00144	1
17	Nipple	RA-00145	1
18	Ball Valve	RA-00217	2
19	Swivel	RA-00218	2
20	Tube	MQ-06016	2
	Hose Cover 10000 mm	MA-00123	
	Insulating Cover 10000 mm	MA-00099	
	Insulating Cover 8000 mm	MA-00099-1	

**(\*) Parts included in the standard assembly of gun.**

## CLEANLINESS KIT (OPCIONAL)



**Figure 11. Cleanliness Kit (Optional)**  
**# KT-00072**

***N.B.: This Kit includes 2 seals Ref. GU-03012 (not shown in the picture).***



**Table 19. Cleanliness Kit, Parts List (OPTIONAL)  
# KT-00072**

Pos.	Description	Reference	Qty.
1	Gun Adapter	GU-02138-00	1
2	Manual Valve Unit	GU-02020-00G	2
3	Input Block Screw	GU-04036	1
4	Male Adapter	RA-00108	1
5	2Lts. Pressurized tank (Standard)	BI-00007-2	1
	10 Lts. Pressurized tank (Optional)	BI-00007-10	1
6	0.5 mts. Air Hose	MA-00097	1
7	Plug	RA-00328	1
8	10 mts. Cleanliness Hose	MA-00063	1

**N.B.:**

***This Kit includes 2 seals Ref. GU-03012 (not shown in the picture)***

***Consult the Marketing department for delivery times for these elements.***



## CONTENT

Warranty	2
Safety and Handling	3
Basic Configurations	4
Specific Configurations for Easy Spray-H	5
Grip and Air Cylinder Assembly	6
Head Assembly	9
Magnetic Plunger Assembly (Optional)	11
Timer Assembly (Optional)	13
Auto Assembly (Optional)	15
Standard Projection Sizes	16
Product Inlet Assembly (Optional)	20
Special Projection Assemblies (Optional)	22
Assembly Pour Adapter (Optional)	26
Recirculation Kit (Optional)	27
Cleanliness Kit (Opcional)	29
Content	31
List of Figures	31
List of Tables	32

## LIST OF FIGURES

Figure 1. Grip and Air Cylinder Assembly, G-DI Gun	6
Figure 2. Head Assembly, G-DI Gun	9
Figure 3. Magnetic Plunger Assembly (Optional)	11
Figure 4. Timer Assembly (Optional), G-DI Gun	13
Figure 5. Auto Assembly (Optional), G-DI Gun	15
Figure 6. Standard Projection Sizes, G-DI Gun	16
Figure 7. Product Inlet Assembly (Optional)	20
Figure 8. Special Projection Assemblies (Optional)	22
Figure 9. Assembly Pour Adapter (Optional)	26
Figure 10. Recirculation Kit (Optional)	27
Figure 11. Cleanliness Kit (Optional)	29



## LIST OF TABLES

Table 1. Grip and Air Cylinder Parts List, _____	7
Table 2. Head Assembly Parts List, _____	10
Table 3. Magnetic Plunger Assembly Parts List (Optional), _____	12
Table 4. Timer Assembly Parts List (Optional), _____	14
Table 5. Auto Assembly Parts List (Optional), _____	15
Table 6. "Round" Projection Size Parts List, _____	16
Table 7. "Flat" Projection Size Parts List, _____	17
Table 8. Configurations According to Application _____	17
Table 9. List of Cleaning Drills for Modules _____	19
Table 10. List of Cleaning Drills for PCD "ROUND" _____	19
Table 11. Product Inlet Assembly Parts List (Optional), _____	21
Table 12. Special Projections Parts List (Optional) _____	23
Table 13. Modular Static Mixer Parts List. _____	24
Table 14. Standard PCD Size List. _____	24
Table 15. Labyrinth Static Mixer Component List. _____	24
Table 16. List of Reversible TIP Sizes. _____	25
Table 17. Assembly Pour Adapter, Parts List (OPTIONAL) _____	26
Table 18. Recirculation Kit Parts List (OPTIONAL) _____	28
Table 19. Cleanliness Kit, Parts List (OPTIONAL) _____	30